

RESOLUTION NO. 2025-24

A RESOLUTION TO REVISE THE RULES, REGULATIONS, RATES AND POLICIES FOR THE CITY OF MARYVILLE, WATER AND SEWER DEPARTMENT.

WHEREAS, Maryville City Council has adopted the Rules, Regulations, Rates and Policy Manual for the City of Maryville, Water and Sewer Department; and,

WHEREAS, it is necessary to modify, remove and clarify certain information in the Rules, Regulations, Rates, and Policy Manual for the City of Maryville, Water and Sewer Department in order to enforce in a fair and equitable manner; and,

WHEREAS, this revision is consistent with the vision and goals of the City of Maryville, Water and Sewer Department.

NOW, THEREFORE, BE IT RESOLVED BY THE CITY COUNCIL OF THE CITY OF MARYVILLE, TENNESSEE, as follows:

SECTION 1. That the Rules, Regulations, Rates, and Policy Manual for the City of Maryville, Water and Sewer Department, be repealed in its entirety and replaced with an updated Manual.

SECTION 2. This resolution shall become effective from and after its adoption:

Adopted this 4th day of November, 2025.



Mayor

ATTEST:



City Recorder

APPROVED AS TO FORM:



City Attorney

RULES, REGULATIONS, RATES AND POLICIES

THE CITY OF MARYVILLE WATER AND SEWER DEPARTMENT

Effective Date: November 4, 2025

Revision History:

- 3/88
- 3/89
- 1/90
- 1/91
- 9/92
- 4/94
- 9/95
- 4/99
- 2/00
- 4/00
- 3/01
- 6/02
- 1/03
- 2/05
- 11/08
- 4/12
- 12/19
- 11/25

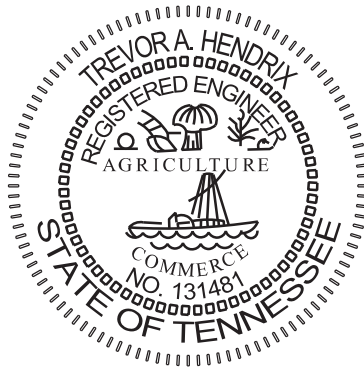

Trevor
A.
Hendrix

Digitally
signed by
Trevor A.
Hendrix
Date:
2026.02.10
08:46:29 -05'00'

WPN25.0669

APPROVED SEWER SPECIFICATIONS

THE DOCUMENT BEARING THIS STAMP HAS BEEN RECEIVED AND REVIEWED BY THE

**TENNESSEE DEPT. OF ENVIRONMENT & CONSERVATION
DIVISION OF WATER RESOURCES**

AND IS HEREBY APPROVED FOR CONSTRUCTION BY THE COMMISSIONER

Tracy Hill

03/05/2026

THIS APPROVAL SHALL NOT BE CONSTRUED AS CREATING A PRESUMPTION OF CORRECT OPERATION OR AS WARRANTING BY THE COMMISSIONER THAT THE APPROVED FACILITIES WILL REACH THE DESIGNED GOALS.

APPROVAL EXPIRES **FIVE YEARS** FROM ABOVE DATE

DW20251094

APPROVED WATER SPECIFICATIONS

THE DOCUMENT BEARING THIS STAMP HAS BEEN RECEIVED AND REVIEWED BY THE

**TENNESSEE DEPT. OF ENVIRONMENT & CONSERVATION
DIVISION OF WATER RESOURCES**

AND IS HEREBY APPROVED FOR USE IN CONSTRUCTION BY THE COMMISSIONER

Cindy Wheeler

03/05/2026

THIS APPROVAL SHALL NOT BE CONSTRUED AS CREATING A PRESUMPTION OF CORRECT OPERATION OR AS WARRANTING BY THE COMMISSIONER THAT THE APPROVED FACILITIES WILL REACH THE DESIGNED GOALS.

APPROVAL EXPIRES **FIVE YEARS** FROM ABOVE DATE

REVISIONS BY

Trevor Hendrix, P.E.

Water and Sewer Engineer – Water and Sewer Department
November 2025 Edition

Jesse McWhorter, P.E.

Engineering and Operations Superintendent – Water and Sewer Department
February 2005, November 2008, December 2019 Edition

Angela M. Luckie, P.E.

Environmental Engineer - Water Quality Control
January 2003 Edition

John H. Graham, Jr., P.E

Assistant Manager - Water Quality Control
April 2000 Edition

Jeffrey A. Rose, P.E.

Assistant Manager - Water Quality Control
September 1995 Edition

Kenneth D. Wiggins, P.E.

Environmental Engineer - Water Quality Control
April 1992 Edition

Originally Prepared in August 1985 by:
Joseph B. Irwin, P.E. - Engineering Department City of Maryville

City of Maryville Water & Sewer Department

Part I Wastewater – November 2025 Revisions Summary

1.1.6 Sewer Easements:

Clarified easement standards by requiring sanitary sewer mains to be located in public right-of-way when feasible, and otherwise within a recorded, dedicated 20-foot minimum easement approved by WSD. Prohibited the use of generic easements for new projects, required easements to be shown on recorded plats, and restricted permanent in-ground structures within easements. Non-permanent improvements such as fences, landscaping, and pavement may be installed at the owner's risk, with repair responsibility on the owner if damaged during sewer work.

1.2.3 Slope:

Established a maximum sewer slope limit of 16 vertical feet per 100 horizontal feet to prevent designs exceeding 18%, which are impractical to construct.

1.2.7 Pipe Bedding:

Revised to require C900 to be completely encapsulated with 6 inches of Size No. 7 crushed stone bedding on the top, bottom, and both sides of the pipe.

1.2.10 and 1.3.4 Manholes:

Required manhole manufacturers to be approved by WSD Engineering, with selection based on historical performance. Directed contractors to the City of Maryville Purchasing Office for the current list of approved suppliers. Clarified that when new sewer mains connect to an existing brick manhole, the brick manhole must be replaced with a precast concrete manhole at the developer's expense. Revised the minimum drop requirement from 24 inches to 30 inches to improve constructability and clarified that all drop assemblies shall be external only.

1.6.1 Requirement for Devices:

Established grease trap requirements for the Downtown zoning district, mandating a 1,000-gallon unit unless space constraints require a smaller approved alternative.

1.6.2 Inspection:

Clarified WSD authority to increase inspection frequency, impose additional maintenance, or require installation of a larger grease trap if deficiencies persist.

1.7.4 Sewer Service Connections:

Limited common service lines to a maximum of two buildings/rooflines by default, with additional connections only allowed if a Tennessee licensed PE certifies adequate capacity. Added clarification on vertical and horizontal spacing requirements for sewer and water lines in the same trench, specifying minimum clearances consistent with IPC standards.

1.7.13 Grinder Pumps

Added grinder pump standards limiting their use to individual properties with access to an existing City gravity main. Permitted only one grinder pump connection per dwelling and prohibited shared systems. Required grinder pumps and private service lines to be owned, operated, and maintained by the property owner, with no responsibility assumed by the City.

1.7.14 Abandonment of Sewer Mains

Added standards for abandonment of sewer mains during development projects. Required geotechnical engineer recommendations with WSD approval. Mandated full removal and stone backfill for mains in roadways, with compacted clay permitted as backfill in greenways or open space.

City of Maryville Water & Sewer Department

Part II Water – November 2025 Revisions Summary

2.1.3 Plans and Specifications Approval: Updated language to specify that all new public water mains, regardless of size, to help prevent vertical separation conflicts and other utility coordination issues during construction.

2.1.9 Water Easements: Clarified water main easement standards by requiring mains to be located in public right-of-way when feasible, and otherwise within a recorded, dedicated 20-foot minimum easement approved by WSD. Prohibited the use of generic easements for new projects, required easements to be shown on recorded plats, and restricted permanent in-ground structures within easements. Allowed fences, landscaping, and pavement at the owner’s risk, with repair responsibility on the owner if damaged during water main work.

2.6.6 Meters: Added standards for irrigation meters. Prohibited private residential irrigation meters, requiring residential irrigation to connect behind the domestic meter, with common green space requests reviewed case-by-case and limited to 5/8-inch. Allowed commercial irrigation meters only upon WSD approval, also limited to 5/8-inch.

2.6.13 Shut-off Valve:

Removed requirement for an additional shut-off valve behind the meter, as this valve is no longer installed due to redundancy.

2.6.21 Fire Hydrant Meters:

Removed fire hydrant meter availability due to repeated issues with meters being damaged or lost after distribution.

2.6.27 Abandonment of Water Mains:

Added standards for abandonment of water mains during development projects. Required geotechnical engineer recommendations with WSD approval. Mandated full removal and stone backfill for mains in roadways, with compacted clay permitted as backfill in greenways or open space.

ARRANGEMENTS OF CONTENTS

PART I	WASTEWATER
PART II	WATER
PART III	SEPTIC TANK EFFLUENT PUMP INSTALLATION GUIDELINES & SPECIFICATIONS
PART IV	SEPTIC TANK EFFLUENT SYSTEMS & FORCE MAINS

Table of Contents

PART I - WASTEWATER	1
1.0 DEFINITIONS	1
1.1. SEWER SYSTEM DESIGN	2
1.1.1. Pre-design Conference	2
1.1.2. Design Period	2
1.1.3. Plans and Specifications Approval	2
1.1.4. Design Factors	6
1.1.5. Design Basis	6
1.1.6. Easements	7
1.2. DETAILS OF DESIGN AND CONSTRUCTION OF WASTEWATER COLLECTION LINES	7
1.2.1. Minimum Size	7
1.2.2. Depth	8
1.2.3. Slope	8
1.2.4. Alignment	8
1.2.5. Increasing Size	8
1.2.6. High Velocity Protection	8
1.2.7. Pipe Bedding	9
1.2.8. Joints and Infiltration	9
1.2.9. Air Pressure Testing	9
1.2.10. Manholes	9
1.2.11. Vacuum Testing	10
1.2.12. Protection of Water Supplies	11
1.2.13. Force mains	11
1.2.14. Wastewater Lift Stations	12
1.3. PRODUCTS	12
1.3.1. Pipe	13

1.3.2.	Pipe Fittings.....	13
1.3.3.	Concrete materials.....	13
1.3.4.	Manholes	14
1.3.5.	Air Release valve	17
1.4.	EXECUTION.....	18
1.4.1.	Preparation	18
1.4.2.	Installing Gravity Sanitary Sewers.....	18
1.4.3.	Final Testing	19
1.4.4.	Installing Manholes.....	20
1.4.5.	Sewer Service Assemblies	21
1.4.6.	Annual Inspection	23
1.4.7.	Bond Requirement.....	24
1.5.	STANDARDS FLEXIBILITY	24
1.5.1.	Interpretations of these Standards and Design criteria.....	24
1.5.2.	Right of Appeal.....	24
1.6.	WASTEWATER GRAVITY INTERCEPTOR DEVICES	24
1.6.1.	Requirement for Devices	24
1.6.2.	Inspection.....	25
1.6.3.	Submittals	25
1.6.4.	Grease Interceptor Size.....	26
1.7.	WASTEWATER RULES, REGULATIONS, & POLICIES.....	26
1.7.1.	Application for Sewer Service	26
1.7.2.	Connection with Sewer Required	26
1.7.3.	Sewer Service Charges	26
1.7.4.	Sewer Service Connections	26
1.7.5.	Customer Service Lines Not To Serve Others	27
1.7.6.	Compliance with International Plumbing Code	28
1.7.7.	Sewer Service with The City And Water From Another Utility Or Well.....	28
1.7.8.	Use of Existing Systems.....	28
1.7.9.	Service Line Stoppages.....	28
1.7.10.	Compliance with Rules And Regulations.....	29
1.7.11.	Extension of Sewer Mains.....	29
1.7.12.	Damage Claims.....	29
1.7.13.	Grinder Pumps	29

1.7.14. Abandonment of Sewer Mains:	30
1.8. WASTEWATER RATES AND CHARGES	30
1.9. SEWER MAIN EXTENSIONS.....	30
1.9.1. Extensions within Existing Developed Areas of the City	30
1.9.2. Extensions within New Subdivisions in the City.....	31
1.9.3. Extensions outside City Limits.....	31
1.9.4. Exception.....	32
PART II - Water	33
2.0 DEFINITIONS	33
2.1 WATER SYSTEM DESIGN.....	35
2.1.1 Description of System Layout	35
2.1.2 Pre-design Conference.....	35
2.1.3 Plans and Specifications Approval	36
2.1.4 Minimum Distributor Pipe Size	37
2.1.5 Fire Protection.....	37
2.1.6 Dead Ends	38
2.1.7 Gate Valves	38
2.1.8 Bends.....	39
2.1.9 Easements	39
2.2 DETAILS OF DESIGN AND CONSTRUCTION OF DISTRIBUTOR MAINS	39
2.2.1 Pipe Support.....	40
2.2.2 Pipe Bedding	40
2.2.3 Rock Excavation	40
2.2.4 Pipe Cover	40
2.2.5 Pipe Alignment.....	40
2.2.6 Hydrostatic Tests.....	40
2.2.7 Disinfection of New Distributor Mains	40
2.2.8 Disinfection When Cutting Into or Repairing Existing Distributor Mains	41
2.2.9 Means of Detecting PVC Pipe	41
2.2.10 Separation of Water Mains and Sewers	41
2.2.11 Surface Water Crossings	42
2.2.12 Cross Connections.....	43
2.2.13 Water Services and Plumbing	43

2.2.14	Relations to Other Utilities.....	43
2.3	PRODUCTS.....	43
2.3.1	General.....	43
2.3.2	Pipe	44
2.3.3	Tees, Crosses and Bends	44
2.3.4	Reducers.....	45
2.3.5	Caps and Plugs	45
2.3.6	Sleeves	45
2.3.7	Valves.....	45
2.3.8	Valve Boxes	46
2.3.9	Blow-off Assemblies.....	46
2.3.10	Fire Hydrants.....	47
2.3.11	Restraint Measures	47
2.3.12	Tapping Sleeves and Valves	48
2.3.13	Cut-in Sleeves and Valves	48
2.3.14	Repair Sleeves and Bands	48
2.3.15	Copper Tubing for Utility Service Lines.....	49
2.3.16	Corporation Stops	49
2.3.17	Copper Service Unions.....	49
2.3.18	Tapped Saddles (For 2-inch PVC Pipe)	49
2.3.19	Service Fittings	50
2.3.20	Water Meters.....	50
2.3.21	Meter Yokes (For 5/8-inch and 1-inch meters).....	51
2.3.22	Meter Boxes	52
2.4	EXECUTION.....	53
2.4.1	Preparation	54
2.4.2	Installing Distributor Pipes.....	55
2.4.3	Installing Appurtenances	55
2.4.4	Installing Water Lines in Street, Highway, and Railroad Rights-of-Way	56
2.4.5	Water Line Pressure Tests.....	56
2.4.6	Water Line Leakage Tests	57
2.4.7	Acceptance of Installation.....	57
2.4.8	Cleaning and Disinfection of Water Lines	57
2.4.9	Water Utility Service Line Connections.....	58

2.4.10	Annual Inspection	58
2.4.11	Bond Requirement	59
2.5	STANDARDS FLEXIBILITY	59
2.5.1	Interpretations of these Standards and Design Criteria	60
2.5.2	Right of Appeal.....	60
2.6	WATER RULES, REGULATIONS, POLICIES	60
2.6.1	Application for Water Service	60
2.6.2	Service Connection and Meter Setting Charges	60
2.6.3	Customers Not To Supply Water To Others.....	60
2.6.4	Deposits.....	61
2.6.5	Rates.....	61
2.6.6	Meters.....	61
2.6.7	Meter Reading and Billing.....	61
2.6.8	Relocation of Meters.....	61
2.6.9	Meter Testing.....	62
2.6.10	Meter Turn On/Off.....	62
2.6.11	Damage To Water Meter	62
2.6.12	Responsibility for Property of Customer.....	62
2.6.13	Shut-off Valve.....	62
2.6.14	Discontinuance of Service	63
2.6.15	Private Fire Lines	63
2.6.16	Swimming Pools	63
2.6.17	No Guarantee of Pressure and/or Supply	63
2.6.18	Fire Hydrants inside Corporate Limit	63
2.6.19	Fire Hydrants outside Corporate Limit.....	64
2.6.20	Fire Hydrants - Private ownership Prohibited.....	64
2.6.21	Fire Hydrant meters	64
2.6.22	Cross-Connections	65
2.6.23	Supply Of Steam Boilers.....	65
2.6.24	Special Service.....	65
2.6.25	Extension of Water Mains.....	65
2.6.26	Responsibility for Damages Incurred To Customer's Water Line	65
2.6.27	Abandonment of Water Mains	66
2.7	WATER RATES AND CHARGES	66

2.8 WATER MAIN EXTENSIONS 66

 2.8.1 Extensions within Existing Developed Areas of the City 66

 2.8.2 Extensions within New Subdivisions in the City..... 67

 2.8.3 Extensions Outside City Limit..... 67

 2.8.4 Exception..... 67

2.9 CROSS CONNECTION ORDINANCE 67

APPENDIX I – DETAIL SHEETS96

APPENDIX II – DEDICATION AND TRANSFER.....98

DEDICATION AND TRANSFER OF UTILITY LINES, EASEMENTS, AND PERTINENT FACILITIES99

APPENDIX III - WATER METERS 101

 Standard for Testing Water MetersAccuracy Limit Chart..... 101

 Test Tanks, Periodic Tests, Records 101

PART I- WASTEWATER

1.0 DEFINITIONS

1. ACCEPTED STREET

A street or avenue located within the City of Maryville which has been accepted by the City for maintenance, or a road or highway located outside the City of Maryville which has been accepted by Blount County.

2. C900

PVC pipe which conforms to the AWWA C900 Standards.

3. CITY

The City of Maryville, Tennessee

4. COST SUMMARY

Total estimated cost of project including all labor and materials costs. Costs will be a combination of material prices and the labor to install them. This is to be broken down to cost per foot of each size of pipe used, fire hydrants, appurtenances, and all miscellaneous items required to complete the construction.

5. CROSS-CONNECTION

Any physical construction whereby the City's water supply is connected with any other water supply systems, whether public or private, or either inside or outside any building in such a manner that a flow of water into the City's water supply is possible, either through the manipulation of valves or because of ineffective check or back-pressure valves, or any other arrangement.

6. CUSTOMER

Any person who receives water and/or wastewater services from the City either under an express or implied contract requiring such person to pay the City for such service.

7. DEVELOPER

Any person, firm or corporation, both public and private, engaged in the development of land, such as subdivisions and other land improvements.

8. DWELLING

Any single structure occupied by one or more persons for residential purposes.

9. EASEMENT

A legally dedicated right-of-way for the City to install water and/or sewer lines within specified boundaries.

10. EXISTING DEVELOPED AREA

A developed area within the corporate limit having streets, water and/or sewer lines and appurtenances, which have been accepted for operation and maintenance by the City.

11. MULTIPLE UNIT DEVELOPMENT

Any multi-unit complex, such as: apartments, small business, etc. on one single parcel.

12. NEW SUBDIVISION

A development of a tract or parcel of land having two or more lots and having dedicated streets which have not been accepted by the appropriate governing agency.

13. PERSON OR TENANT

Firms and corporations, as well as individuals.

14. PREMISES

Any structure or group of structures, including land, operated as a single business or enterprise.

15. UNIT

An individual part of a multiple unit development.

NOTE:

Whenever the context shall admit or require words used herein in the singular shall include the plural; words used in the plural shall include the singular; words used in the masculine shall include the feminine; and words used in the feminine shall include the masculine.

1.1. SEWER SYSTEM DESIGN

1.1.1. Pre-design Conference

Prior to the design of a wastewater collection system extension, the design engineer should first confer with the City of Maryville Development Services regarding growth potential and density that may be expected in the general area of the extension being planned. A conference with the Water and Sewer staff should follow to discuss system standards and requirements, as well as any problems related to the mains being extended. The design engineer must have a license to practice in the State of Tennessee.

1.1.2. Design Period

In general, wastewater collection extensions shall be designed for the estimated ultimate tributary population.

1.1.3. Plans and Specifications Approval

(a) Detailed plans and specifications for a proposed extension must be submitted along with the cost summary to the Water and Sewer Department of the City of Maryville for approval. Once approval has been obtained, the detailed plans and specifications must be submitted to the Tennessee Department of Environment & Conservation, Division of Water Resources, for approval. Upon completion of the project, the **design engineer** shall revise the detailed plans to reflect "As-Built" information and submit the revisions for review to the Water and Sewer Department. Upon acceptance of the

"As-Built" the **design engineer** shall provide an electronic copy of the "As-Built" submitted in a format that can be edited in AutoCAD and a PDF or other electronic file type as requested by WSD personnel. Additionally, the **design engineer** may be required to furnish the Water and Sewer Department with one paper copy of the "As-Built" drawing. Drawings to be furnished in Engineering format no larger than 22 inches x 34 inches.

- (b) Each plan sheet shall bear an appropriate title block showing the name of the project, location, owner, engineer, date, scale in feet, true north where applicable, sheet number and revision data.

Each sheet shall contain a blank area at least 4 inches by 6 inches near the title block for imprinting the official "Approved for Construction" stamps of the Tennessee Department of Environment & Conservation and WSD Engineering of the City of Maryville. Plans shall be clear and legible and shall conform to the requirements of WSD Engineering's Standards.

- (c) Plans of Sewers:

A plot plan of the existing and proposed sewers shall be submitted for projects involving substantial additions to the existing sewer system. The plan shall show the location, size and direction of flow of all existing and proposed sewers. Hydraulic calculations are required for all lines in the project.

All lines receiving discharge from the project shall be shown to be adequate. A vicinity map must accompany all sewer line extensions. For projects involving multiple sewer lines, include a project map showing the overall layout of the entire project.

- (d) Detail Plans:

Detail plans shall be submitted. Plans and profiles are required for all wastewater lines. Profiles should have a horizontal scale of not more than 50 feet to the inch. The vertical scale of profiles shall not be more than 10 feet to the inch. The plan view should be drawn to a corresponding horizontal scale. Plans and profiles shall be drawn on the same sheet and will show:

1. Location of streets and sewers; lines for the existing and proposed ground surface; location and description of survey benchmarks; size, material and type of pipe for the main and service lines; length between manholes; invert and surface elevation at each manhole; location and size of service lines and taps; and grade of sewer between each two adjacent manholes. All manholes shall be numbered on the plans and correspondingly numbered on the profiles. Stationing of the sewer line at 100-foot intervals and locations of all appurtenances by stationing shall be shown on the plan and profile. Where there is any question of the sewer being sufficiently deep to serve any residence or other source, the elevation and location of the basement floor or other low point source shall be plotted on the profile of the sewer which is to serve the house or source in question. The engineer shall state that all sewers are sufficiently deep to serve adjacent basements or sources

except where otherwise noted on the plans. Whenever possible, sewer service lines shall discharge into a manhole.

2. Locations of all special features such as inverted siphon, concrete encasements, elevated sewers, etc.
3. All known existing structures both above and below ground which might interfere with the proposed construction, particularly water mains, gas mains, storm drains, etc.
4. No other utilities shall be drawn on the sheet except for clarification or reference.
5. Sufficient detail shall be shown on the plans to allow for materials take off and location of lines in the field by a third party.

(e) The following note(s) must be included in the plan sets:

THESE PLANS ARE BASED ON AN ACTUAL FIELD SURVEY AND LAYOUT OF THE SEWER SYSTEM. THE MEASUREMENTS GIVEN AND LAYOUT SHOWN ARE SUFFICIENT FOR ORDERING OF MATERIALS AND FIELD LAYOUT OF THIS PROJECT. ALL ELEVATIONS NOTED FOR MANHOLES AND APPURTENANCES ARE ACTUAL FIELD MEASURED ELEVATIONS.

THE CONTRACTOR SHALL NOTIFY TENNESSEE ONE CALL AT LEAST 72 HOURS PRIOR TO ANY EXCAVATION FOR UTILITY LINE LOCATES. ANY DISCREPANCIES BETWEEN THE PLAN LOCATIONS AND THE ACTUAL FIELD LOCATIONS SHALL BE IMMEDIATELY COMMUNICATED TO THE DESIGN ENGINEER AND THE CITY OF MARYVILLE, WATER AND SEWER ENGINEERING.

(f) Erosion Prevention and Sediment Control (EPSC)

1. Construction projects resulting in one or more acres of soil disturbance or less than one acre as part of a larger common plan of development comprising at least one acre of cumulative land disturbance are required to obtain authorization under the National Pollutant Discharge Elimination System (NPDES) General Permit for Discharges of Stormwater Associated with Construction Activities (CGP) or an individual NPDES permit. Construction activities include clearing, grading, filling, and excavating. Site operators must maintain coverage under this permit for all portions of a site that have not been permanently stabilized.
2. CGP Notice of Intent (NOI) and supporting documentation are required at the time of construction document submittal. The NOI is processed at the local field office and a copy of the NOI or the permit tracking number shall be included with the plan's submittal. EPSC measures shall be designed in accordance with the current version of the TDEC Erosion and Sediment Control Handbook.
3. Clearing, grubbing, and other disturbances to riparian vegetation and wetlands shall be kept at the minimum necessary for slope construction and equipment operations.

4. Sediment shall be prevented from entering the waters of the state.
 5. All spoil materials from trench excavation, bore pits, and other earth-disturbing activities shall be deposited in an upland location and stabilized within seven days in order to prevent erosion into the waters of the state.
 6. All dewatering activities shall be conducted in such a manner as to prevent the discharge of sediment-laden water into waters of the state.
 7. To minimize wildlife entanglement and plastic debris pollution, temporary erosion and sediment control products that either do not contain netting, or that contain netting manufactured from 100 percent biodegradable non-plastic materials such as jute, sisal, or coir fiber shall be specified. Netting used in these products should have a loose-weave wildlife-safe design with movable joints between the horizontal and vertical twines, allowing the twines to move independently. Degradable, photodegradable, UV-degradable, oxo-degradable, or oxo-biodegradable plastic netting (including polypropylene, nylon, polyethylene, and polyester) are not acceptable alternatives.
- (g) Design considerations for crossings involving trenches parallel to streams and wetlands
1. Trench Plugs:
 1. Trench plugs are barriers placed within an open pipeline excavation in order to slow flow and reduce erosion in the trench and to prevent the trench from becoming a subsurface drainage path. Since the bedding and embedment are constructed using cohesionless, free-draining soils, a path is created for water to flow easily (French drain effect) alongside the pipe. In areas where there is high groundwater, where the pipeline crosses streams or aquifers, or where the natural groundwater flow would be affected or even diverted by the select material, trench plugs of impervious materials should be constructed at intervals along the pipeline.
 2. The trench plug area will have a bedding of impervious materials, whereas the bedding on both sides of the trench plug will have a bedding of uncompacted, cohesionless soil.
 3. Location and spacing of trench plugs: Minimum of one trench plug between manholes, and one trench plug at each end of the stream crossing or wetland. The trench plugs between manholes shall be located near the upstream manhole.
 2. Aerial Crossings:
 1. Sewers that lay on piers across ravines or streams may be allowed if no other practical alternative exists or, in the design engineer's judgment, other methods will not be as reliable.

2. Support shall be provided for all joints in pipes utilized for aerial crossings. The supports shall be designed to prevent frost heave, overturning, and settlement.
3. Provide precautions against freezing, such as insulation and increased slope.
4. Provide expansion joints between above-ground and below-ground sewers. Where buried sewers change to aerial sewers, use special construction techniques to minimize frost heaving.
5. For aerial stream crossings, the impact of floodwaters and debris shall be considered. The bottom of the pipe should be placed no lower than the elevation of the 50-year flood. Ductile iron pipe with mechanical joints is recommended.
6. The design should consider maintenance of an adequate waterway for the 100-year flood flows and analyze the impact of the proposed aerial crossing(s) on flooding, including hydraulic modeling, such as Hydrologic Engineering Center-River Analysis System (HEC-RAS) modeling, as necessary.

1.1.4. Design Factors

- (a) In determining the required capacities of sanitary sewers, the following factors must be considered:
 1. Maximum hourly quantity of wastewater
 2. Additional maximum wastewater from industrial plants
 3. Ground water infiltration.

1.1.5. Design Basis

- (a) Per capita flow: Sewer systems serving residential development should be designed on the basis of an average daily per capita flow of wastewater of not less than 100 gallons per day when no water use information is available. This amount of flow is assumed to cover nominal infiltration, but an additional allowance should be made where conditions are unfavorable.

Generally the sewers shall be designed to carry, when running full, not less than the following daily per capita contributions of wastewater, exclusive of wastewater from industrial plants:

1. Laterals and sub-main sewers: 400% of average design flow
2. Main, trunk and outfall sewers: 250% of average design flow

1.1.6. Easements

- (a) General requirements: Sanitary sewer mains shall be located within public right-of-way wherever feasible. When placement in right-of-way is not possible, sewer mains may be installed on private property only where the developer owns the property or has obtained a recorded, dedicated sanitary sewer easement from the property owner.

The easement shall provide sufficient width to accommodate the sewer main, maintenance activities, and future replacement. The City of Maryville WSD requires a minimum width of 20 feet for sanitary sewer easements, unless a greater width is deemed necessary by WSD Engineering based on main depth, maintenance access or other design factors.

Easement alignment shall be reviewed and approved by WSD Engineering to ensure compliance with design standards, maintenance access, and long-term system integrity.

- (b) New development: Easements shall be identified on the recorded plat.
- (c) Cross-lot easements: When a sewer main must cross private property to provide service to another property, the developer shall obtain a dedicated sanitary sewer easement from each affected property owner. The easement must be recorded prior to construction and meet all requirements in this section.
- (d) General utility, drainage & utility, or other non-specific easements shall not be used for sanitary sewer installation unless the recorded easement document explicitly grants sanitary sewer rights and allows access for construction, operation, maintenance, and replacement. Existing recorded general easements that were previously accepted by WSD shall remain valid; however, new projects shall be required to obtain a dedicated sanitary sewer easement.
- (e) Restrictions: No permanent in-ground structures (including buildings, retaining walls, pools, or footings) shall be installed within sanitary sewer easements. Surface features such as fences, landscaping, and pavement may be installed at the owner's risk, provided they do not restrict access for maintenance and repair. Any surface features damaged or removed during sewer main work shall be the owner's responsibility to repair or replace.

1.2. DETAILS OF DESIGN AND CONSTRUCTION OF WASTEWATER COLLECTION LINES

1.2.1. Minimum Size

No sewer collection line shall be less than 8 inches in diameter.

1.2.2. Depth

Sewers shall be deep enough to drain basements and to prevent freezing. Any exception must be approved by WSD Engineering. Where practical, a minimum depth of 5 feet shall be maintained.

1.2.3. Slope

a) Minimum Slope: All sewers shall be so designed and constructed to give mean velocities, when flowing half full, of not less than 2.0 feet per second. The minimum required slopes for 8-inch through 18-inch sewer mains are shown below. However, these slopes, should be used only when required. All sewers shall be laid with uniform slope between manholes.

SEWER SIZE (inches)	RECOMMENDED MINIMUM SLOPES (Feet/100 Feet)
8	0.50
10	0.39
12	0.30
14	0.12
15	0.11
16	0.10
18	0.09

b) Maximum Slope: All sewers shall be designed and constructed that the slope shall not exceed 16 vertical feet per 100 horizontal feet.

1.2.4. Alignment

Sewers shall be designed with straight alignment between manholes.

1.2.5. Increasing Size

When a smaller sewer joins a larger one, the invert of the larger sewer should be lowered sufficiently to maintain the same energy gradient. An acceptable approximate method for securing these results is to place the 0.8 depth point of both sewers at the same elevation.

1.2.6. High Velocity Protection

C900 pipe shall be used when slopes are greater than:

SEWER SIZE (inches)	SLOPE (Feet/100 Feet)
10	13'
12	9'

1.2.7. Pipe Bedding

(a) All sewers shall be designed to prevent damage from superimposed loads. Proper allowance for loads on the sewer shall be made because of the width and depth of trench. Backfill material from a foot above the pipe should not exceed 6 inches in diameter at its greatest dimension. In roadways where cover is less than 4 feet, or in open areas where cover is less than 2½ feet, C900 shall be used. C900 shall be required when sewer installation occurs in areas of non-virgin soil (i.e. areas of "fill"). Piers shall be provided for when necessary for support. A precast impermeable barrier or concrete encasement shall be used at the transition from fill to virgin soil to prevent piping of water through the crushed stone bedding. For structural reasons, C900 or relocation shall be required when culverts or other conduits are laid such that the top of the sewer is less than 18 inches below the bottom of the culvert or conduit. Special care shall be used in placing bedding in the haunching region.

C900 and SDR 26/ASTM D3034 PVC Pipe: Each sewer pipe section shall be completely encapsulated with 6 inches of bedding material on the top, both sides, and the bottom of the pipe. Bedding materials shall be Size No. 7 crushed stone.

(b) Sewer lines laid in fill shall be:

1. C900 , and
2. installed on piers.

This requirement may be waived in whole or in part by WSD Engineering if sufficient compaction has been achieved in the fill (95% AASHTO T-99 minimum).

1.2.8. Joints and Infiltration

Sewer joints should be designed to minimize infiltration and to prevent the entrance of roots. Standard laying lengths for PVC pipe shall not exceed 14 feet and 20 feet if C900.

1.2.9. Air Pressure Testing

Low pressure air exfiltration testing of all pipes shall be performed on all line segments. The pressure drop during the testing period shall be a maximum of 0.2 psig after initial pressure stabilization in the line segment. Minimum test time shall be 5 minutes for each line segment.

1.2.10. Manholes

(a) Location: manholes shall be installed at the upper end of each collection sewer line, at all changes in horizontal and vertical alignment, at points of changes in size, and at all

pipe intersections. Manholes shall be installed at distances not greater than 350 feet apart. Any exception shall require permission from Maryville WSD Engineering.

- (b) Drop Manholes: A drop pipe shall be provided for a sewer entering a manhole at an elevation of 30 inches or more above the manhole invert. Where the difference in elevation between the incoming sewer and the manhole invert is less than 30 inches, the invert should be U-shaped to prevent deposition of solids. All drop manholes shall be constructed as per the detail drawings. The upper horizontal entry line for all drop manholes shall be C900 pipe and shall extend from the manhole wall to the tee and from the tee a minimum of one full joint of pipe. The drop assembly shall consist of a C900 tee with appropriate gaskets for the material used. Only outside drop assemblies will be approved.
- (c) A drop pipe of C900, a 90 degree bend, a C900 pipe connection into the bottom of the manhole. The lower 90 degree bend and lower horizontal line shall be fully supported by 3,000 psi minimum strength concrete that is poured against native ground with a minimum unconfined compressive soil strength of 2,000 pounds per square foot.
- (d) Diameter: the minimum diameter of manholes shall be 48 inches. The entrance tube shall be at least 24 inches in diameter.
- (e) The manhole manufacturer shall be subject to approval by Maryville WSD Engineering. Only manufacturers approved by Maryville WSD Engineering shall be used for construction. Determination is to be made by Maryville WSD Engineering based on historical performance. Contact the City of Maryville Purchasing Office for the approved list of suppliers.

1.2.11. Vacuum Testing

Vacuum Testing shall be conducted on each wet well, and/or manhole. The test shall be performed such that the integrity of each component (i.e. pipe connections, seal(s) between manhole sections, seal between manhole and frame) is verified.

Prior to testing, all pipe inlets and outlets shall be plugged and braced. A vacuum of ten (10) inches of mercury shall be drawn and the vacuum pump shut off. With no additional vacuum added by the pump, the wet well/manhole assembly will be accepted if the time measured for the vacuum to drop to nine point five (9.5) inches does not violate the table below. If these times are exceeded, repairs shall be made, or manhole parts replaced until the test times are met. Any apparent leaks in the manhole as determined by the inspector shall be sealed and the manhole re-tested.

MINIMUM TIMES FOR WETWELL/MANHOLE VACUUM TEST (Seconds)*

DEPTH (FEET)	<4	6	8	10	12	14	Each Additional 2 feet
DIAMETER	TIME OF TEST						
48 inches	10	15	20	25	30	35	5
60 inches	13	20	27	34	41	48	7
72 inches	16	24	32	40	48	56	8
96 inches	22	33	44	55	66	77	11

*Other diameters to be as per current ASTM C1244.

1.2.12. Protection of Water Supplies

- (a) Water Supply Interconnections: There shall be no physical connection between a potable water supply line and a sewer or appurtenance thereto which would permit the passage of any wastewater or polluted water into the potable supply.
- (b) Relation to Other Utilities: There shall be no other utility lines installed in the same trench parallel to existing water or sewer lines.
- (c) Relation to Water Mains:
 - 1. Horizontal Separation: Whenever possible, sewers (gravity and force mains) should be laid at least 10 feet horizontally from any existing or proposed water pipe. Should local conditions prevent a lateral separation of 10 feet, a sewer may be laid closer than 10 feet to the water main if it is laid in a separate trench and if the elevation of the top of the sewer pipe is at least 18 inches below the bottom of the water pipe.
 - 2. Vertical Separation: Whenever a sewer (gravity and force mains) must cross under a water main, the sewer shall be laid at such elevation that the top of the sewer is at least 18 inches below the bottom of the water main. When the elevation of the sewer cannot be varied to meet the above requirement, the water main shall be relocated to provide the separation or reconstructed with ductile iron pipe for a minimum distance of 10 feet on each side of the sewer. At least one full length of water main should be centered over the sewer so that both joints shall be as far from the sewer as possible.
 - 3. When it is impossible to obtain proper horizontal and vertical separation as stipulated above, the sewer shall be constructed of C900 pipe and shall be pressure-tested to assure water tightness.

1.2.13. Force mains

- (a) Velocity: At design flow, velocity in excess of two feet per second shall be maintained.
- (b) Air Release Valve: An automatic air release valve shall be placed at high points in the force main to prevent air-locking.

- (c) Termination: Force mains shall terminate in the invert of a manhole.
- (d) Pipe Diameter: Force mains are to be designed and sized for the pump they are serving.
- (e) A maximum Hazen and Williams "C" factor used should not be greater than 130 regardless of that actually determined for the pipe.
- (f) Force mains using minimum 4-inch AWWA C-900 DR18 PVC slip-on type joint meeting the latest requirements of AWWA Standards C151 with a minimum of 3 feet of cover will be acceptable to the Maryville Water and Sewer Department.
- (g) All force mains shall include a connection manhole within twenty (20) feet of the pump station on the discharge line that will allow for the connection of a pump station bypass pump to the force main. Said connection shall include an appropriately sized tee, reducer as needed, corrosion resistant gate, or ball valve (PVC preferred) and a four-inch quick connect coupling compatible with the City of Maryville hydraulic portable pump hoses. The connection shall be housed in a standard manhole with drainage provided in the bottom of the manhole to prevent flooding of the connection.
- (h) When AWWA C-900 DR-18 PVC pipe is used, 12 gauge toning wire shall be installed along the entire length of the pipe for detection. The ends of the wire shall terminate in a valve box or other acceptable location whereby detection equipment may be attached. PVC or other GREEN plastic warning tape labeled "SEWER" shall be installed approximately midway in the trench prior to backfilling with soil. Locate stations shall be placed at a maximum of 1,000 foot intervals.

1.2.14. Wastewater Lift Stations

Wastewater lift station design criteria is not provided under these Standards. However, lift stations shall be of the wet well/dry sump configuration. Construction of the lift station shall include a paved (asphalt or concrete) driveway, minimum 8-foot high chain-link fence enclosing the site, minimum 20-foot wide gate for access, a permanent potable water supply, radio SCADA units compatible with the existing City of Maryville SCADA system. The wet well of the wastewater lift station shall be constructed to allow for the insertion of a portable Gorman Rupp hydraulic pump without interference from the suction elbows for emergency pumping conditions. A flat area in the bottom of the wet well shall be provided of sufficient size to allow the hydraulic pump to be set in place on the pump station floor without induced tilt on the pump and without having to remove the normal wet well piping. Maryville WSD Engineering will evaluate separately the materials and criteria proposed for use in the design of wastewater lift stations. Plans and specifications must be submitted to the Maryville WSD Engineering for approval. Once approval has been given by the Maryville WSD Engineering, plans and specifications must be submitted to the Tennessee Department of Environment & Conservation, Division of Water Resources, for approval.

1.3. PRODUCTS

Pipe and all accessory fitting and appurtenances, etc., shall be made in America where possible unless approval is obtained from the Maryville WSD Engineering for the use of a

product that is not made in America. This requirement shall be construed in a manner, which does not violate current trade agreements, any amendments thereto, or any other free trade or other laws.

1.3.1. Pipe

PVC Pipe:

1. Shall be manufactured from virgin, NSF approved resin conforming to the requirements of ASTM Standard D1784.
2. All PVC Pipe shall conform to the requirements of either:
 - i. ASTM Standard D3034 or ASTM F-679 and have a Standard Dimension Ratio (SDR) of 26 or,
 - ii. AWWA Standard C900.
3. The gaskets used for joining PVC sewer pipe shall conform to ASTM Standard F477.
4. All PVC pipe shall be clearly marked with the manufacturer's name, nominal diameter, SDR, ASTM D3034; or AWWA C900 and NSF approved seal.
5. Use of ASTM D3034/SDR26 PVC pipe shall be limited to depths less than or equal to sixteen (16) feet. Where depths to the sewer invert exceed sixteen (16) feet, C900 pipe shall be used.

1.3.2. Pipe Fittings

- (a) PVC pipe fittings shall be manufactured from virgin, NSF approved resin conforming to the requirements of ASTM Standard D-1784.
- (b) Fitting for Connections Between Dissimilar Pipe materials.
 1. When laying uphill and transitioning from SDR 26 PVC C900 PVC pipe, a cast iron or ductile iron mechanical joint sleeve will be installed. Appropriate gaskets for the pipes joined shall be used.
 2. When laying uphill and transitioning from C900 to SDR26, a cast iron or ductile iron mechanical sleeve will be installed. Gaskets shall be appropriate for the pipes joined.

1.3.3. Concrete materials

Concrete used in conjunction with the installation or repair of sewer lines and appurtenances shall be as follows:

1. Minimum compressive strength: 28 days, 4,000 psi average any 3 cylinders.
2. Coarse aggregates: Size No. 57 crushed limestone.

3. Fine aggregates: Natural sand or manufactured limestone sand proportioned by dry weight of fine to total aggregates between 30-45 percent.
4. Slump: 2-4 inches.
5. Mixing Water: maximum 6.0 gallons per sack. Deduct the moisture content of the aggregate from the amount of mixing water required.
6. Cement: Use Portland cement meeting the requirements of ASTM Standard C150. Use minimum 6.6 sacks of cement per cubic yard of concrete.
7. Dry aggregate per cement sack: Coarse aggregate 280, fine aggregate using manufactured limestone sand-194, fine aggregate using natural sand-187.

1.3.4. Manholes

(a) General Requirements

Manholes shall be precast reinforced concrete meeting the requirements of ASTM Standard C478 except as may be provided otherwise in the following: (See Appendix I for standard drawings)

1. Manhole inside diameter shall be 48 inches for 18 inch and lesser diameter pipe and 60 inches for 21 inch to 30-inch diameter pipe.
2. Wall thickness shall be a minimum of 5 inches.
3. The minimum compressive strength of precast manhole risers, bases, cone or top sections, and grade rings shall be 4,000 psi.
4. The access opening in cone or top sections shall be a minimum of 24 inches.
5. Joints: The reinforced concrete manhole base and riser sections, excepting grade rings, shall be formed with male and female ends, so that when the manhole base, riser, and top are assembled they will make a continuous and uniform manhole.
6. Lift eyes or holes may be provided in each section for the purpose of handling but must not protrude through the concrete walls.
7. Polyethylene manholes, or fiberglass manholes may be used with prior permission of the WSD Engineering.
8. The outside surface of manhole bases, risers, and cones, shall be completely coated with bituminous coating as required.
9. Manhole joints and parts shall be compatible with the majority of the existing City of Maryville precast manholes and capable of meeting the vacuum testing requirements without field modifications.

10. The manhole manufacturer shall be subject to approval by Maryville WSD Engineering. Only manufacturers approved by Maryville WSD Engineering shall be used for construction. Determination is to be made by Maryville WSD Engineering based on historical performance. Contact the City of Maryville Purchasing Office for the approved list of suppliers.

02. Precast Reinforced Concrete Manhole Bases:

1. The base riser sections shall be precast with integral floors.
2. Bases for pipe 10 inches diameter or less shall have a minimum outside height of 24 inches.
3. Bases for 12 inch through 18-inch diameter pipe shall have a minimum outside height of 36 inches.
4. Heights of bases for pipes greater than 18 inches in diameter shall be according to the manufacturer's specifications, subject to prior approval of the WSD Engineering.

03. Precast Reinforced Concrete Tops:

Precast tops shall be eccentric cone type. Flat slab tops may be used with PRIOR approval by WSD Engineering.

04. Precast Reinforced Concrete Grade Rings:

1. Grade ring wall thickness shall be a minimum of 5 inches.
2. Grade rings shall be either 2 inches, 4 inches, 6 inches, 8 inches or 12 inches in height.
3. The combined height of grade rings shall be a maximum of 12 inches.

05. Concrete Manhole Coating: The outside surface of manhole bases, risers, and cones may be coated with 2 layers of bituminous coating applied at right angles to each other as required.

06. Manhole Steps:

1. Manhole steps shall be aluminum fabricated from aluminum alloy 6061, T6.
2. Manhole steps shall be corrosion resistant, free from sharp edges, burrs, or other projections which may be a safety hazard and shall be of sufficient strength to have a live load of 300 pounds imposed at any point.
3. The minimum width of cleat shall be 10 inches.

4. The legs and struts shall be of sufficient length for the cleat to project a minimum clear distance of 4 inches from the wall when the step is securely imbedded in the manhole wall.
 5. The top surface of the cleats shall be designed to prevent foot slippage.
 6. Steps should be positioned vertically over a pipe inlet/outlet and at a maximum spacing of 16 inches.
 7. Steps shall be the same size, projection, spacing, and alignment in each manhole.
07. Section Joints: Base risers, section risers, and tops shall be designed for flexible butyl resin sealant meeting the latest requirements of AASHTO Standard M198-B.
08. Pipe Entrance Couplings:
1. Openings in the base section wall shall be factory installed for the required number and size of pipes and shall be manufactured as to allow up to 20 degrees axial deflection as shown on the approved plan.
 - i. Internal expanding bands or power sleeves shall be of a type 304 stainless steel meeting the latest requirements of ASTM Standard C923 and shall be designed to allow contraction around the boot to clamp and seal the boot to the pipe.
 - ii. The pipe entrance coupling shall be Kor-N-Seal™ 106-406 Series, or approved equal meeting ASTM Standard C923 shall be installed for each core opening furnished in the base or riser sections.
 2. Pipe openings made in the field in existing manhole walls for PVC or C900 pipe installation shall be one of the following:
 - i. Concrete manholes shall be cored in the field. Each core shall have installed a flexible molded neoprene compound boot meeting the requirements of section 1.3.4 (h) 1. of these standards.
 - ii. Whenever new sewer main lines are to connect to an existing brick manhole, the manhole shall be replaced with a precast concrete manhole at the developer's expense.

09. Manhole Frames and Covers:

(See Appendix I)

1. Manhole frames and covers shall be of gray cast iron meeting the latest requirements of ASTM Standard A48, Class 30, (30,000 psi). The total weight of the frame and cover shall not be less than 375 pounds for a standard height frame or 200 pounds for a shallow height frame.
2. Manhole covers shall be round and machine ground horizontally.

3. Manhole frames shall have clear openings of 24 inches, heights 7-8 inches for standard rings, or 4-5 inches for short rings, and overall base diameters between 35 & 37 ½ inches. The base shall have four uniformly spaced holes for attachment to the manhole using 5/8-inch diameter bolts. The maximum bolt circle diameter shall be 33 inches.
4. Manhole covers shall have a thickness as specified by manufacturer and diameters of 26 inches.
5. Manhole covers shall have two non-penetrating pick holes for lifting purposes.
6. The top face of the manhole covers shall be embossed with the seal of the City of Maryville and the words "SANITARY SEWER" with letters approximately two (2) inches in size.
7. Painting of the inside frame and lid may be required.
8. Manhole frame and cover dimensions and specifications are shown on standard detail Sheet 1 in Appendix I.

10. Watertight Manhole Covers:

(See Appendix I)

1. Watertight manhole frames and covers shall be of the outer lid/inner watertight cover configuration.
2. The frame and outer lid shall meet the requirements of Section 1.3.4 (i) of these Standards.
3. The steel locking bar for the inner watertight cover shall be equipped with a minimum 3/4-inch diameter stainless steel bolt for securing the cover. The bolt shall be equipped with a minimum 1/2-inch diameter, 4-inch long "tee" handle for installation and removal.
4. The inner watertight cover shall be equipped with two (2) cast iron, stainless steel, or brass eyehooks for ease of removal and installation of the cover.
5. A watertight seal between the inner cover and frame shall be achieved using a minimum 3/8-inch diameter O-ring gasket. This gasket shall be set in a groove in either the inner cover or the frame. The groove shall be at least one half the diameter of the O-ring gasket. If the gasket is set in the inner lid, then it shall be attached to the inner lid so that it will not fall off while removing the lid.
6. Watertight manhole frame and cover dimensions and specifications are shown on standard detail Sheet 1 in Appendix I.

1.3.5. Air Release valve

Air release valves for use on pressure sewage mains shall be Vent-O-Mat™. Series RGX or approved equal. Each valve shall be designed/sized for its particular application. Reference

the standard detail drawing in Appendix I. Valves are to be located outside of paved areas whenever possible and graded to assure positive drainage away from the valve installation. Rodent screens are required on all vent lines. Perforated lids may be substituted for the vent lines with the Maryville WSD Engineering approval.

1.4. EXECUTION

- (a) All construction on the City of Maryville's wastewater collection system that is not performed by the Maryville WSD shall be executed by a person, firm, or corporation licensed to engage in municipal utility contracting as set forth in the Tennessee Contractors Licensing Act of 1976 (TCA 62-601). This requirement shall apply to all construction regardless of the amount of work involved.
- (b) Contractors shall hold the appropriate license designation for the work they are to perform and a valid City of Maryville or Blount County Business License.

1.4.1. Preparation

- (a) Precautions and Permit to Excavate:
 - 1. Notify utility companies to locate existing facilities.
 - 2. Abide by other utility companies' requirements when repairing, replacing or disturbing existing facilities.
 - 3. Prior to trench excavation within any public right-of-way, including public alleys, a permit shall be obtained from the governing authority to perform such excavation. As a minimum, the trench backfill and street repair shall be made in accordance with the Maryville Land Development and Public Works Standards.
- (b) Prior to laying pipe, prepare suitable bedding in accordance with 1.2.7 of these Standards.
- (c) Before placing pipe in trench, field inspect for cracks or other defects; remove defective pipe from construction site.
- (d) Swab the interior of the pipe to remove all undesirable material.
- (e) Prepare the bell end and remove undesirable material from the gasket and gasket recess.

1.4.2. Installing Gravity Sanitary Sewers

- (a) Lay pipe true to the lines and grades from the grade and alignment stakes, or equally usable references. Laser equipment shall be used and offset hubs shall be provided at each manhole for purpose of checking grade between sections.
- (b) Accurately establish the centerline of each pipe using current construction methods.

- (c) Carefully inspect all pipe and each fitting prior to its placement in the trench, and reject any defective pipe or fitting from the job site.
- (d) Lay pipe progressively upgrade, with bell upstream in such a manner as to form close, concentric joints with smooth bottomed inverts. Joining of all pipe shall be in accordance with manufacturer's specifications.
- (e) Bed and/or support each pipe section in accordance with Section 1.2.7 of these Standards.
- (f) Provide all gravity sewer lines with a minimum of 4 feet of cover in roadways and 2.5 feet of cover in open areas, unless C900 pipe is used.
- (g) Do not allow walking on completed pipelines until backfill has been placed to a depth of at least 6 inches above the crown of the pipe.
- (h) Keep the pipe free of all unneeded material, and upon completion of a section between any two manholes, it shall be possible to view a complete circle of light when looking through the pipe.
- (i) When laying pipe ceases, close the open ends of the pipe with a suitable plug for preventing the entrance of foreign materials.
- (j) Couplings and adapters used for joining dissimilar gravity pipe materials for repairing and rejoining sections of gravity sewer shall be of neoprene construction with stainless steel clamps.
- (k) Couplings used to repair damage that occurs during new construction shall be hard coupling of the original material.

1.4.3. Final Testing

- (a) Before the sewer line is accepted and before any houses are connected, a final testing procedure is to be followed.
- (b) Perform a visual inspection. A TV-inspection of the line may be required. All leaks shall be repaired.
- (c) A low-pressure air exfiltration test shall be made.
 - 1. Such tests will be conducted in accordance with ASTM C 828. Procedures for a low-pressure air exfiltration test are provided under Section 1.2.9 of these Standards.
- (d) When PVC pipe is used, pulling an approved "go -no go" deflection mandrel of 95/100 pipe diameter through all reaches of gravity sewer is required. No sections will be accepted that exhibit a deflection of more than five (5%) percent. Test shall not be made until a minimum of 24 hours has passed since the fill over the pipe was completed.

1.4.4. Installing Manholes

- (a) Manholes shall be furnished as provided under Section 1.3.4 of these Standards.
- (b) Depth of manholes shall be the vertical distance from the lowest invert in the manhole to the base of the manhole cover frame.
- (c) Backfill manholes with the same material used for pipelines.
- (d) Prepare manhole subgrade on undisturbed earth. Remove all loose earth prior to placing crushed stone base or concrete slab. Fill all disturbed areas below subgrade level with compacted bedding stone.
- (e) Manholes having a depth of less than 12 feet shall be set on a compacted Size No. 7 crushed limestone base of minimum 6 inches thickness. Manholes having a depth of 12 feet or more shall be set on a 6-inch thick concrete slab having a minimum diameter 1 foot greater than the outside diameter of the manhole base section (6 foot by 6 foot square or 7 foot round pad for a standard 4 foot manhole). The concrete pad shall be precast and set on 6 inches compacted Size No. 7 crushed stone bedding. Precast slab must be Size No. 4 rebar 12 inches on center or the equivalent area of approved reinforcement material. Concrete shall meet the conditions of Section 1.3.3 of these standards.
- (f) The crushed limestone base shall be placed on dry consolidated and, when possible, undisturbed soil. Where a manhole cannot be installed on undisturbed soil or where field inspection shows a soft subgrade, the engineer shall design a footer that will support the manhole and prevent damage to the sewer line due to differential settling.
- (g) Manholes shall be set plumb.
- (h) Manhole inverts shall be accurately shaped, using concrete, to a smooth surface texture. Invert flow channels shall be shaped having the same radii as those of the pipes for which the channels are being provided. The depth of the channels shall be a minimum of 1/2 the diameter of the pipes being accommodated. From the edge of the shaped flow channels to the manhole walls, inverts shall be sloped upward at a minimum of 1 to 6.
- (i) Inlets and outlets of each manhole shall be finished smooth and flush with the sides of the manhole wall so as not to obstruct the flow of wastewater through the manhole.
- (j) When completed, the manhole shall be free from channel obstruction and leakage.
- (k) Seal joints between manhole sections with flexible butyl resin sealant. Manufacturer's recommendations for placing sealant shall be followed.
- (l) Lift holes shall not completely penetrate the manhole walls.
- (m) Precast concrete grade rings shall be set using Portland Cement mortar and/or flexible butyl resin sealant. Care should be exercised so as not to allow too much water in the

Portland Cement Mortar which may cause shrinkage. All Manhole cover frames that are attached to 2 or 4 inch grade rings shall be attached to the grade rings using Portland Cement Concrete mortar and/or butyl resin sealant. A minimum of 2-inch thickness of mortar shall also be placed over the lip of the cover frame as shown on standard drawings. Joints of precast concrete grade rings and manhole frames shall be made so as to prevent leakage and pass vacuum testing.

Alternate attachment for 6 inches in height grade rings and direct attachment to the manhole cone:

The following alternate may be used in lieu of Portland cement mortar for attaching Manhole Frames to grade rings 6 inches in height or directly to the manhole cone. Manhole Frames shall be bolted by means of 4, 5/8 inch anchor bolts and shall be set in a bed of flexible butyl resin sealant. No Portland Cement Mortar will be required around the frame when this alternative is used.

(n) Drop Manholes:

1. The drop pipe construction shall be of C900 pipe and C900 fittings. The inlet piping of an outside drop shall be bedded with concrete to solid or virgin ground. The remainder of the outside drop shall be backfilled with compacted Size No. 7 crushed stone. C900 pipe shall meet the requirements of Section 1.3.1 of these Standards. Fittings shall meet the requirements of Section 1.3.2 of these Standards. One full joint of C900 pipe shall be installed prior to the drop assembly.
2. Concrete used in constructing drop pipe assemblies shall meet the conditions under Section 1.3.3 of these Standards.

(o) Flexible couplings shall be packed with Portland Cement Mortar. The use of bricks or other materials to fill the flexible coupling "boot" is not allowed.

1.4.5. Sewer Service Assemblies

- (a) Fittings shall be furnished and installed by the developer in the gravity sewer pipes for individual service assemblies for any and all existing lots and/or lots to be platted in the development.
1. The standard collector tap shall consist of a tee connected with a 6-inch diameter branch. The tap will consist of fittings made of the same material as that of the line except that PVC fittings may be used on vitrified clay lines. C900 pipe and C900 fittings shall be used in roadways where cover is less than 4 feet, or in open areas where cover is less than 2.5 feet. Also, C900 pipe shall be used where velocities greater than 15 feet per second are attained.
 2. Sewer service assemblies having 45 degree angles or less measured from the horizontal may be used when the depth of the sewer collector is greater than 8 feet or when their use will facilitate connection of individual services.

3. All sewer service assemblies having angles of 30 degrees or greater measured from the horizontal shall be placed-in a bedding of compacted Size No. 7 crushed stone having a minimum width of 3 times the pipe diameter, a minimum thickness under the pipe equal to the pipe diameter, and an overall thickness of twice the pipe diameter. A minimum of 6 inches of bedding stone shall be placed above the top of all PVC risers in accordance with the provisions of Section 1.2.7 of these standards.
4. Tee branches not to be used immediately shall be plugged with stoppers of the same material and joints used on the collector lines.

(b) Service Pipe and Fittings:

1. Service pipe and fittings shall be supplied by the developer and shall have a minimum diameter of 6 inches and shall be installed from the collector lines to the street right-of-way lines or edges of easements provided. Building sewer shall be located on the lot itself. In cases where other utilities or structures are present the service line shall be required to be extended beyond the interfering structures. The decision as to extending the service line shall be made in the field by the City of Maryville WSD Engineering personnel. Service pipe and fittings shall meet the conditions under Section 1.2 of these Standards.
 2. Ends of service pipe shall be plugged and covered the same as collectors, where possible.
 3. The minimum grade on service pipes shall be one percent or 1/8 inch per foot.
 4. Service pipes shall be bedded in accordance with the provisions of Section 1.2.7 of these Standards.
 5. Ends of service pipes shall be field located (1) by recording the distances measured along the collector lines from the nearest downstream manhole to points at right angles to such service pipe ends and recording the perpendicular distances measured between the collector lines and the service pipe ends and, (2) by installing a length of 2-inch diameter PVC pipe at the service pipe ends, placed at the end of the assembly and protruding 4 feet above the ground surface vertically above such service pipe ends. (See Appendix I for Standard drawings).
- (c) The 6-inch branch sewer service assembly shall be extended to the lot it is intended to serve as per (b) above. Minimum 6-inch sewer service pipe grade is 1%. The sewer service pipe grade may be increased provided that the lowest buildable corner of the lot may be served from the end of the 6-inch service pipe under the following assumptions:
1. On Lot service pipe grade 2% from end of the 6-inch branch sewer service pipe to the furthest buildable corner.
 2. Minimum depth at furthest buildable corner 2 feet.

3. Or a minimum finish floor elevation for service shall be established by the engineer and included in the final plat.
- (d) Design of new sewer mains to provide services at existing homes and new subdivisions shall include:
1. Physical verification of the invert elevation of existing "on lot" sewer lines.
 2. Statement by the design engineer in cases where the house sewer cannot be connected to the gravity sewer without a pump.
 3. Where feasible, the sewer line shall be deep enough to serve existing and roughed in plumbing and the proposed lots by gravity connections.

1.4.6. Annual Inspection

Approximately twelve (12) months following acceptance of the utility line, a follow-up inspection will be made to determine if any failures or deficiencies have occurred as a result of Contractor's or Developer's work and/or materials. Present at this inspection will be a representative of the Maryville WSD Engineering and a notice of the inspection with its findings shall be forwarded in writing to the Developer. The Developer will be responsible for correction of all failures or deficiencies of a mechanical nature and for failures or deficiencies caused by the work and/or materials of Developer and/or his agents which occur in the first year of operation. Any other failures or deficiencies which occur in the first year of operation will be the responsibility of the title owner of the affected property except that any failures or deficiencies on property dedicated to the City of Maryville by the Developer shall remain the responsibility of the Developer throughout the one year warranty period. The Developer and/or property owner, as appropriate, is further responsible for any additional damages done in completing the required repairs. Within ninety (90) days of notification of the findings of the one-year inspection, it is the responsibility of the Developer and/or property owner as appropriate to ensure that any and all changes and/or repairs have been completed. If the Developer is in compliance and no changes or repairs are needed either initially or within the ninety (90) day cure period, any bond posted shall be returned to the Developer within sixty (60) days of completion and acceptance of the work by the City following the one year inspection. If the Developer fails to complete any required repairs or changes and the ninety (90) day cure period passes after notice, any bond posted shall be paid immediately to the City of Maryville for the purpose of remedying any of the deficiencies and/or for completion of the project. Such funds shall remain the sole property of the City of Maryville, even to the extent that the actual costs of the work done are less than the amount of the bond forfeited to compensate the City of Maryville for the additional time and manpower needed to complete the work or to see that the work is completed. Maryville WSD Engineering will oversee completion of the needed work at the expense of Developer and will charge Developer any overage incurred over the bond amount for the cost of the completed work. The Developer is responsible for such charges. If a bond has not been provided, the City may file suit or make other collection efforts against the Developer or any other appropriate parties immediately after the expiration of the ninety (90) day cure period for the cost of the work done or to be done to bring the property into compliance. The City

shall receive from the Developer or any other appropriate party its reasonable litigation costs incurred as a result of Developer and/or other appropriate defendant failing to timely complete the required repairs identified in the one-year inspection. Such litigation costs include, but are not limited to, reasonable attorney's fees, court costs and deposition fees.

1.4.7. Bond Requirement

Maryville WSD Engineering shall maintain a list of delinquent developers who are in default and have not in the past performed repairs required by the City of Maryville or WSD Engineering after the ninety (90) day cure period following the inspection done at the one year warranty period. These developers shall be required to perform or pay for the required repair work and any and all prior projects for which the developer is responsible; otherwise, the developer will be required to post a performance bond acceptable to WSD Engineering before commencement of any new projects involving WSD Engineering. Such bond shall be in an amount equal to at least ten percent (10%) of the contracted cost of the water and sewer utility installation for the development. The performance bond shall be payable to the City of Maryville and shall be executed by a surety company duly authorized and qualified to do business in the State of Tennessee. This bond shall be conditioned upon the developer's completion of all requirements of WSD Engineering as set forth in any contractual agreement with the City and in the Rules, Regulations, Rates and Policies for the City of Maryville, Water and Sewer Department pertaining to warranty work and required repairs to the water, sewer, and wastewater utility systems for the project.

1.5. STANDARDS FLEXIBILITY

1.5.1. Interpretations of these Standards and Design criteria

Interpretations of these Standards and Design Criteria or the determination of any other Maryville WSD Engineering standards and design criteria not covered under these Standards shall be at the discretion of the Public Utility Director of the Maryville WSD Engineering. The decision of the Public Utility Director of Maryville WSD Engineering shall be based on past practices, traditional policies, widely accepted professional principles and practices of the industry.

1.5.2. Right of Appeal

Any disagreement with the interpretations or determinations made by the City of Maryville Public Utility Director with respect to these Standards or any other standards not covered herein may be appealed to the City Manager.

1.6. WASTEWATER GRAVITY INTERCEPTOR DEVICES

1.6.1. Requirement for Devices

(a) Commercial or industrial dischargers of wastewater into the City of Maryville wastewater collection system are required by the Sewer Use Ordinance, International

Plumbing Code, as adopted and amended from time to time by the City or other ordinance or regulation of the City of Maryville to install and maintain a gravity-type separator, interceptor, or other such device for the removal of oil, grease, sand, grit, entrails, or other such material likely to create or contribute to a blockage of the wastewater collection system or otherwise interfere with the operation of the sanitary sewer system or the Regional Wastewater Treatment Plant (RWWTTP).

- (b) Commercial establishments which are not required to install such devices include, but are not limited to:
 - 1. Commercial establishments which are not involved in food processing, preparation, packaging, or handling;
 - 2. Commercial establishments with food preparation, but no deep fryer, or grill;
- (c) Although these establishments are initially excluded from the device requirement, if it is determined that these businesses are causing sewer line stoppages due to grease or other problems, then gravity interceptor devices shall be required. If a commercial establishment plans to add a deep fryer or a grill, that establishment must notify the City prior to installation and submit plans as specified in Subsection 1.6.3 of this section.
- (d) Downtown zoning district: 1,000-gallon grease trap is required unless sufficient space for installation is not available. If space limitations prevent installation of a 1,000-gallon unit, a passive under-sink grease trap or an automatic grease trap may be used, subject to approval by WSD Engineering.

1.6.2. Inspection

Each commercial or industrial user required to own and maintain such devices shall be inspected at least twice each year to determine the maintenance and operation of these systems. Maintenance records shall be kept and shall be available for review by WSD Engineering during inspections. WSD reserves the right to increase inspection frequency or impose additional maintenance requirements if, upon inspection, the devices are found to be improperly maintained, malfunctioning, or otherwise not in compliance with City standards. WSD further reserves the right to require installation of a larger grease trap if additional maintenance requirements do not resolve these deficiencies.

1.6.3. Submittals

Prior to installation of new gravity-type separators, grease interceptor, screens, or other pretreatment devices, plans and design calculations shall be submitted to WSD Engineering for review and approval. No specifications for pretreatment devices are detailed in these regulations except for grease interceptor. Grease interceptor specifications are outlined on standard detail drawing Sheet 2 in Appendix I, and in Subsection 1.6.4 of this section. WSD Engineering will evaluate separately the materials and criteria proposed for use in the design of other pretreatment devices.

1.6.4. Grease Interceptor Size

Grease interceptor sizes will be determined by the following formula:

Grease Interceptor Size (gallons) = F.U. x 0.5 x 5 gpm x 20 minutes

Where:

F.U. = fixture units plumbed into the grease interceptor
(fixture unit values as list in the Southern Building Code)

gpm = gallons/minute

Minimum grease interceptor size shall be 1,000 gallons

1.7. WASTEWATER RULES, REGULATIONS, & POLICIES

1.7.1. Application for Sewer Service

Persons desiring sewer service connections shall make application to the City. The application shall state that the applicant shall abide by the Rules, Rates and Charges of the City then in force, or which thereafter is adopted. The application shall be signed by the owner or tenant of the premises, and shall state the location of the premises to be served, including street, lot number, and relevant elevations of the main floor or basement so that the City can determine the availability of service.

1.7.2. Connection with Sewer Required

In accordance with the City of Maryville Municipal Code, Title 18, Chapter 2, regulating the use of public and private sewers, owners of all houses, buildings, or properties used for human occupancy, employment, recreation, or other purposes situated inside or outside City limits and abutting on any street, alley or right-of-way in which there is located a public sanitary sewer of the City, and is within three hundred (300) feet of the building drain are hereby required, at their expense, to connect such houses, buildings or properties to the City's public sanitary sewerage system. Connections over 300 ft should be considered a main extension.

1.7.3. Sewer Service Charges

All water customers of the City whose premises are connected with the sanitary sewerage system shall pay sewer service charges in accordance with the Customer Service Policy Manual.

1.7.4. Sewer Service Connections

All service connections to an existing City sewerage system shall be made at suitable locations selected by authorized personnel of the City or our designated representative. The City will establish proper grades for service connections when required. The sewer

service line shall be installed from the existing sewer main to the edge of the right-of-way or edge of easement.

The sewer connection charge is shown in the Customer Service Policy Manual. A charge must be paid upon application for service for each connection or tap to be made to the City sewerage system. Houses, buildings or properties having one roof line and containing multi occupancy units may be connected to the City system by means of a single connection or tap, providing such single connection or tap is shown to have adequate capacity to carry the maximum quantity of sewage in accordance to the International Plumbing Code, as adopted and amended from time to time by the City.

A maximum of two buildings or rooflines may be connected to one common service line on a single parcel. Additional buildings or rooflines may only be connected if capacity calculations are provided by a Tennessee licensed professional engineer demonstrating that the line has adequate capacity to carry the maximum quantity of sewage in accordance with the International Building Code (minimum 6-inch service). Before a parcel with a common line can be subdivided, the sewer line shall be upgraded to the standards of Section 1.2 above in order to serve multiple parcels.

The service line or building sewer shall be within the property lines of the applicant and shall be installed, owned, and maintained at the expense of the applicant. A minimum of eighteen (18) inches of cover shall be maintained over all service lines. Where sewer and water service lines are installed in separate trenches, a minimum horizontal separation of five (5) feet shall be maintained. Where local conditions prevent this separation, both lines may be placed in the same trench provided that at least eighteen (18) inches of horizontal separation is maintained, and the water line is laid at least eighteen (18) inches above the sewer line.

1.7.5. Customer Service Lines Not To Serve Others

A separate and independent building sewer shall be provided for every platted lot served. Said building sewer shall be located on the lot itself. (Building sewer is defined as "That part of the drainage system that extends from the end of the building drain and conveys the discharge to a public sewer, private sewer, individual sewage disposal system or other point of disposal," except as defined in section 1.7.4 above.)

Note: State of Tennessee Department of Environment and Conservation (TDEC) requires that any sewer collection system be permitted for operation. A sewer collection system is any common sewer line that accepts flow from more than one lot.

Specifically, TDEC requires:

- (a) The collection system must be permitted by TDEC.
- (b) The collection system must have an operator certified by the TDEC Board of Water and Wastewater Operator Certification.
- (c) The collection system must be a legally established and liable operating entity.

- (d) The collection system must make all appropriate reports and pay all appropriate fees to the State of Tennessee.
- (e) The collection system must have in place an agreement from an appropriate publicly owned treatment works to accept the sewage from the collection system.

This does not prohibit multiple connections to a line provided the line is operated by a certified collection system operator as part of a TDEC permitted collection system.

1.7.6. Compliance with International Plumbing Code

The customer shall be responsible for installing and maintaining his service line in compliance with the International Plumbing Code as adopted and amended from time to time by the City. Should the Plumbing official or WSD Engineering representative or his authorized inspector determine the customer's service line needs to be rehabilitated or replaced, it shall be the responsibility of the customer to perform the necessary corrective work.

1.7.7. Sewer Service with The City And Water From Another Utility Or Well

Customers connected to the City sewerage system but not connected to the City water system, will be charged for sewer service based on metered water used, if obtainable. If the customer has water service from a source other than the City and fails to pay the City for sewerage service, the City has the right to disconnect or plug his sewer service line serving the property.

Single dwelling customers served by an unmetered water supply and connected to the City sewerage system shall pay a monthly flat rate sewerage charge in accordance with rates shown in the Customer Service Policy Manual.

Multi-dwelling customers served by an unmetered water supply and connected to the City sewerage system shall pay a monthly charge per unit in accordance with the rates as shown in the Customer Service Policy Manual.

Commercial customers shall meter their water supply regardless of the water source to establish the sewer charge.

1.7.8. Use of Existing Systems

All cesspools, privies, and septic tank systems in use in the City may continue to be used if kept in a proper and sanitary condition until such time as a sewer shall be constructed in a public right-of-way or easement abutting the property containing such systems, after which said properties shall be connected to the City system.

1.7.9. Service Line Stoppages

The City's personnel will unstop the City service line serving the customer's premises at the expense of the City. It will be the responsibility of the customer to unstop blocked service lines on the customer's service; however, in the event there is some doubt as to location

of the stoppage, the City may unstop the line. Should the City determine that the blockage was located on the customer's service; the customer shall pay for actual cost of unstopping the line by the City crew.

1.7.10. Compliance with Rules And Regulations

The City can, at its discretion, discontinue services to those customers who fail to comply with the foregoing Rules and Regulations, ordinances, Resolutions, or any other policy of the City that may apply.

1.7.11. Extension of Sewer Mains

The extension of gravity sanitary sewer mains shall be made in accordance with and subject to the conditions as set forth in accordance with our current Water and Wastewater Fee Schedule.

1.7.12. Damage Claims

Maryville WSD Engineering shall not accept responsibility for damages incurred by a customer of WSD Engineering, when said damages have resulted from the following actions:

- (a) damages caused by defective operation or condition of the customer's plumbing system;
- (b) damages caused by a defective condition in the wastewater system, unless the department receives actual or constructive notice of the defective condition.

All claims resulting from negligent operation, negligent installation, or negligent repairs, and all claims arising out of sudden and unexpected emergency repair work, will be handled on a case by case basis within the scope of the Tennessee Municipal League Risk Management Pool policies, and within the scope of general law, including the Tennessee Municipal Tort Liability Act.

1.7.13. Grinder Pumps

Grinder pumps may be utilized to provide wastewater service to individual properties only where a public City gravity sanitary sewer main is available for connection. Grinder pumps shall not be permitted as a means of providing sewer service to properties without access to an existing City gravity sewer main.

Grinder pumps shall be located entirely within the limits of the property they serve and shall discharge directly into the City gravity sanitary sewer main via an individual service line. One grinder pump connection (tap) shall be permitted per dwelling. Shared force mains, shared grinder pump systems, shared lower pressure systems serving more than one parcel are prohibited.

Grinder pumps and individual service lines located on private property shall be owned, operated, and maintained entirely by the property owner. The City of Maryville shall have

no responsibility for the ownership, operation, maintenance, or replacement of grinder pumps installed on private property.

1.7.14. Abandonment of Sewer Mains:

When an existing sewer main is to be abandoned as part of a development project, the method of abandonment shall be based on recommendations provided by a licensed geotechnical engineer and shall be subject to review and approval by WSD Engineering.

Sewer mains located within roadways shall be completely removed, and the trench shall be backfilled with clean Size No. 7 crushed stone. In greenways or open space areas, compacted clay may be used as backfill.

1.8. WASTEWATER RATES AND CHARGES

Rates, fees and other charges for the sanitary sewer system will be in accordance with current City of Maryville fee schedule as located in the Customer Service Policy Manual. Fees not included in the above policies will be charged based on actual costs.

1.9. SEWER MAIN EXTENSIONS

In addition to the following regulations, each proposed water and/or sanitary sewer extension shall be evaluated for acceptance or rejection, especially sewer main extensions involving a sewage lift station(s). The merits of which an extension is evaluated shall include, but not be limited to, the following:

1. Cost of operations and maintenance of equipment;
2. Projected revenues from utility sales generated as a direct result of the extension;
3. Concerns with respect to the environment and/or ecology; and
4. Overall budget considerations.

In general, and insofar as possible, each extension should be economically viable and self-sustaining on its own with minimal impact on the utility ratepayers as a whole.

1.9.1. Extensions within Existing Developed Areas of the City

The City may extend sewer mains within the existing developed areas (existing platted lots of record) along accepted streets and easements within the corporate limit of the City of Maryville where economically feasible or where there exists a threat to public health caused by gross pollution resulting from inadequately operating or overflowing underground sewage disposal fields, and where the City can feasible provide sufficient funds for such extensions.

Should the City determine that the design capacity of the line should be increased to allow the service of areas other than that of the applicant, the City will pay the difference

between the cost (including installation) of the line sized for the applicant versus the cost of the main to serve the expanded area. The size of such larger mains shall be at the discretion of the City.

The City may connect a main to or extend a main from any main previously installed in accordance to the above terms without obligation to the applicant who may have borne the expense on such previously installed main.

Sewer extensions into the Westwood Subdivision may be constructed where feasible after 75% of the potential customers along the proposed route have petitioned WSD Engineering to provide sanitary sewer service. Upon completion construction of the line, each customer to which sanitary sewer service has been made available shall connect to the sewer and pay the applicable construction contribution in addition to the regular tap fees and capacity charges as set forth in the Customer Service Manual.

In no event will the City make any extension at its expense should the operating budget of Maryville WSD not have sufficient funds for such extension.

1.9.2. Extensions within New Subdivisions in the City

All sewer main extensions within new subdivisions being developed within the corporate limit of the City of Maryville shall be installed by and at the expense of the developer. However, should the City determine that the design capacity of the line should be increased to allow the service of the areas other than the development; the City will pay the difference between the cost of the line sized for the development (including installation) versus the cost of the main to serve the expanded area. The size of such larger mains shall be at the discretion of the City.

The City may connect a main to, or extend a main from any main previously installed in accordance with the above terms without obligation to the developer of the newly developed subdivision.

1.9.3. Extensions outside City Limits

All proposed sewer main extensions outside the City of Maryville must be granted approval to proceed from the City prior to preparation of plans. The City reserves the right to reject any extensions.

All sewer main extensions outside the City of Maryville shall be installed by and at the expense of the Developer from the end of the existing sewer main whether it is inside or outside the City limits. However, if the City determines that it is in the best interest of the City, it may install or have installed said extensions and charge the developer a lump sum fee which shall include all applicable connection fees and line extension construction costs. Also, should the City determine that the design capacity of the line should be increased to allow the service of areas other than the development, the City will pay the difference between the cost (including installation) of the line sized for the development versus the cost of the main to serve the expanded area. The size of such larger mains shall be at the discretion of the City.

The City may connect a main to, or extend a main from, any main previously installed in accordance with the above terms without obligation to the developer or consumer who previously installed such main.

1.9.4. Exception

The regulations governing the extension of sewer mains shall not limit the City from participating in the cost of sewer main extensions when the application warrants consideration due to high volume consumption or favorable return on investment.

PART II- Water

2.0 DEFINITIONS

1. ACCEPTED STREET

A street or avenue located within the City of Maryville, which has been accepted by the City for maintenance, or a road or highway located outside the City of Maryville which has been accepted by Blount County.

2. BACKFLOW

The undesirable reversal of flow of a liquid, gas, or other substance in a potable water distribution piping system as a result of a cross connection.

3. BACKFLOW PREVENTER

An assembly, device, or method that prohibits the backflow of water into potable water supply systems.

4. CITY

The City of Maryville, Tennessee

5. COST SUMMARY

Total estimated cost of project including all labor and materials costs. Costs will be a combination of material prices and the labor to install them. This is to be broken down to cost per foot of each size of pipe used, fire hydrants, appurtenances, and all miscellaneous items required to complete the construction.

6. CROSS-CONNECTION

A connection or a potential connection between any part of a potable water system and any other environment containing other substances in a manner that, under any circumstances, would allow such substances to enter the potable water system. Other substances may be gases, liquids, or solids, such as chemicals, water products, steam, water from other sources (potable or non-potable), or any matter that may change the color or add odor to the water. Bypass arrangements, jumper connections, removable sections, swivel or changeover assemblies, or any other temporary or permanent connecting arrangement through which backflow may occur are considered to be cross-connections.

7. CUSTOMER

Any person who receives water and/or wastewater services from the City either under an express or implied contract requiring such person to pay the City for such service.

8. DEVELOPER

Any person, firm or corporation, both public and private, engaged in the development of land, such as subdivisions and other land improvements.

9. DOUBLE CHECK DETECTOR BACKFLOW-PREVENTION ASSEMBLY (DCDA)

A specially designed backflow assembly composed of a line-size-approved double check

valve assembly with a bypass containing a specific water meter and an approved double check valve assembly. The meter shall register accurately for very low rates of flow up to 3 gpm and shall show a registration for all rates of flow. This assembly shall only be used to protect against a non-health hazard (i.e., a pollutant). The DCDA is primarily used on fire sprinkler systems.

10. DOUBLE CHECK VALVE ASSEMBLY (DC OR DCVA)

A complete assembly consisting of two internally loaded, independently operating check valves, located between two tightly closing resilient seated shutoff valves with four properly placed resilient-seated test cocks. This assembly shall only be used to protect against a non-health hazard (i.e., a pollutant).

11. DWELLING

Any single structure occupied by one or more persons for residential purposes.

12. EASEMENT

A legally dedicated right-of-way for the City to install water and/or sewer lines within specified boundaries.

13. EXISTING DEVELOPED AREA

A developed area within the corporate limit having streets, water and/or sewer lines and appurtenances which have been accepted for operation and maintenance by the City.

14. HEALTH HAZARD (HIGH HAZARD)

A cross-connection or potential cross-connection involving any substance that could, if introduced into the potable water supply, cause death or illness, spread disease, or have a high probability of causing such effects.

15. MULTIPLE UNIT DEVELOPMENT

Any multi-unit complex, such as: apartments, small business, etc. on one single parcel.

16. NEW SUBDIVISION

A development of a tract or parcel of land having two or more lots and having dedicated streets which have not been accepted by the appropriate governing agency.

17. NON-HEALTH HAZARD (LOW HAZARD)

A cross-connection or potential cross-connection involving any substance that generally would not be a health hazard but would constitute a nuisance or be aesthetically objectionable if introduced into the potable water supply.

18. PERSON OR TENANT

Firms and corporations, as well as, individuals.

19. POTABLE WATER

Water that is safe for human consumption as described by the public health authority having jurisdiction.

20. PREMISES

Any structure or group of structures, including land, operated as a single business or enterprise.

21. REDUCED-PRESSURE PRINCIPLE BACKFLOW-PREVENTION ASSEMBLY (RP OR RPBA OR RPA OR RPZ)

A complete assembly consisting of a mechanical, independently acting, hydraulically dependent relief valve, located between two independently operating, internally loaded check valves that are located between two tightly closing resilient-seated shutoff valves with four properly placed resilient seated test cocks.

22. REDUCED-PRESSURE PRINCIPLE DETECTOR BACKFLOW PREVENTION ASSEMBLY (RPDA)

A specially designed backflow assembly composed of a line-size-approved reduced-pressure principle backflow-prevention assembly with a bypass containing a specific water meter and an approved reduced-pressure principle backflow-prevention assembly. The meter shall register accurately for very low rates of flow up to 3 gpm and shall show a registration for all rates of flow. This assembly shall be used to protect against a non-health hazard (i.e., a pollutant) or a health hazard (i.e., a contaminant). The RPDA is primarily used on fire sprinkler systems.

23. SERVICE CONNECTION

A piping connection between the water purveyor's main and a customer's service line.

24. SERVICE LINE

UTILITY - Water line from the water main connection to the water meter.

CUSTOMER - Water line from the water meter connection to the building.

25. UNIT

An individual part of a multiple unit development.

NOTE:

Whenever the context shall admit or require words used herein in the singular shall include the plural; words used in the plural shall include the singular; words used in the masculine shall include the feminine; and words used in the feminine shall include the masculine.

2.1 WATER SYSTEM DESIGN**2.1.1 Description of System Layout**

The layout of extensions of the Maryville Water and Sewer Department System from a design concept, for convenience, will be the circle or belt system circumventing smaller crossover or gridiron systems.

2.1.2 Pre-design Conference

Before beginning a system extension design, the design engineer should first confer with the City of Maryville in regard to the growth potential and density that may be expected in the general area of the extension being planned. A conference with the WSD Engineering staff should follow to

discuss the system standards and requirements as well as any problems related to the mains being extended.

2.1.3 Plans and Specifications Approval

- (a) Detailed plans and specifications for a proposed extension must be submitted along with the cost summary to the Water and Sewer Department of the City of Maryville for approval. Once approval has been obtained, the detailed plans and specifications must be submitted to the Tennessee Department of Environment & Conservation, Division of Water Resources, for approval. Upon completion of the project, the design engineer shall revise the detailed plans to reflect "As-Built" information and submit the revisions for review to the Water and Sewer Department. Upon acceptance of the "As-Built" the design engineer shall provide an electronic copy of the "As Built" submitted in a format that can be edited in AutoCAD and a PDF or other electronic file type as requested by WSD personnel. Additionally, the design engineer may be required to furnish Water and Sewer Department with one paper copy of the "As-Built" drawings. Drawings to be furnished in Engineering format no larger than 22 inches x 34 inches.
- (b) Each plan sheet shall bear an appropriate title block showing the name of the project, location, owner, engineer, date, scale in feet, true north where applicable, sheet number, revision date, and other information as may be required. Each sheet shall contain a blank area at least 4 inches by 6 inches near the title block for imprinting the official "Approved for Construction" stamps of the Tennessee Department of Environment and Conservation and the Maryville Water and Sewer Department. Plans shall be clear and shall conform to the requirements of the Maryville Water and Sewer Department Standards.
- (c) Plans of Water mains: A plot plan of existing and proposed water mains shall be submitted for projects involving substantial additions to the existing water distribution system. The plan shall show the location and size of all proposed water mains. A vicinity map must accompany all water main extension plans. A project layout map showing the entire project shall be required if extensions are shown on more than one sheet.
- (d) Detailed Plans: Plans should have a scale based on increments of ten but not more than 100 feet to the inch and must show:
 - 1. Locations of streets and water mains, size of mains, location and size of utility service lines, material and type of pipe.
 - 2. All known existing structures both above and below ground which might interfere with the proposed construction, particularly sewer lines, gas mains, storm drains, etc.
 - 3. Stationing of the water line at 100-foot intervals and locations of all appurtenances by stationing.
 - 4. No other utilities shall be drawn except for clarification or reference.

5. Sufficient detail shall be shown on the plans to allow for materials take off and location of lines in the field by a third party.
 6. Profiles shall be drawn for all proposed water mains.
- (e) The following note(s) must be included in the plan sets:

THESE PLANS ARE BASED ON AN ACTUAL FIELD SURVEY. THE MEASUREMENTS GIVEN AND LAYOUT SHOWN ARE SUFFICIENT FOR ORDERING OF MATERIALS AND ACTUAL FIELD LAYOUT OF THIS PROJECT. THE CONTRACTOR SHALL NOTIFY TENNESSEE ONE CALL AT LEAST 72 HOURS PRIOR TO ANY EXCAVATION FOR UTILITY LINE LOCATES. ANY DISCREPANCIES BETWEEN THE PLAN LOCATIONS AND THE ACTUAL FIELD LOCATIONS SHALL BE IMMEDIATELY COMMUNICATED TO THE DESIGN ENGINEER AND THE CITY OF MARYVILLE, WATER AND SEWER DEPARTMENT.

2.1.4 Minimum Distributor Pipe Size

- (a) The minimum size pipe shall be 8-inch diameter except for the following instances:
1. 6-inch pipe will be permitted when looped in a grid and no leg of such grid exceeds 800 feet in length.
 2. Dead-end 6-inch lines may be permitted at lengths of 600 feet and less provided the minimum flow requirements of Section 2.1.4(b) of these standards are met, and provided it has been determined by the Maryville Water and Sewer Department that there will never be a future need for its extension.
 3. Water line extensions utilizing PVC pipe shall not be allowed.
- (b) The size of pipe shall be justified by hydraulic analysis performed by an engineer who holds a valid license to practice in the State of Tennessee. Distributor pipes should be capable of providing a minimum flow of 750 gallons per minute (gpm). The distributor pipe shall be designed to maintain a minimum pressure of 30 pounds per square inch (psi) at ground level at all points in the system under all conditions of flow.
- (c) All assumptions and any flow data used by the design engineer must be clearly documented and submitted with the hydraulic calculations. If actual flow data are not available, theoretical calculations shall be based on all storage facilities being half-full and the appropriate Hazen and Williams friction factor shall be applied for the type pipe being used, but in no case shall such friction factor be greater than 130 throughout the new pipe network.
- (d) Distributor pipes should be sized for an instantaneous peak demand of 750 gpm.

2.1.5 Fire Protection

- (a) Fire hydrants should not be connected to distribution pipes that are not capable of providing a flow of 750 gpm at a residual pressure of 30 psi.

- (b) When fire protection is being provided, fire hydrants shall be located at points designated by the Fire Department and the Water and Sewer Department of the City of Maryville.
- (c) The minimum pipe size to which a fire hydrant may be connected is 6-inch.
- (d) The minimum standards for privately-owned sprinkler lines shall be the following:
 - 1. Constructed of Class 51 ductile iron pipe for unmetered system.
 - 2. Low hazard, non-metered fire protection systems will require an approved above ground Double-Check Detector Backflow-prevention Assembly (DCDA).
 - 3. High hazard, non-metered fire protection systems will require an approved above ground Reduced Pressure Principle Detector Backflow-prevention Assembly (RPDA).
 - 4. Metered low hazard fire protection systems will require an approved above ground Double-Check Valve Assembly (DC or DCVA).
 - 5. Metered high hazard fire protection systems will require an approved above ground Reduced- Pressure Principle Backflow-prevention Assembly (RP or RPBA or RPA or RPZ).
 - 6. Should devices be installed outside the facility, devices must be freeze protected.

2.1.6 Dead Ends

- (a) Dead ends shall be minimized.
- (b) Water lines within residential, commercial, and industrial developments shall be extended to the exterior property line(s) where it has been determined by the Water and Sewer Department that there will be a future need for their extension.
- (c) Water lines within residential, commercial, and industrial developments shall be extended and connected to lines within the existing water distribution system when required to achieve the flow requirements of Section 2.1.4(b) of these Standards.
- (d) Where dead end distributor pipes occur, they shall be provided with a fire hydrant.

2.1.7 Gate Valves

- (a) Unless otherwise specified by the Water and Sewer Department, gate valves shall be placed at all intersections of distributor pipes. Two valves shall be placed at each tee; one installed in the run and the other installed in the branch. Three valves shall be placed at each cross. Valves should be positioned in the pipeline approximately 3 feet distance from the tee or cross.

- (b) Valves at no time shall be placed greater than 3,000 feet apart unless otherwise specified by the Water and Sewer Department. At the discretion of Water and Sewer Department, valves in remote locations may be required to be permanently marked.
- (c) Valves shall be placed on lead-outs approximately 3 feet from fire hydrants.

2.1.8 Bends

Bends in 6-inch pipe and greater shall be minimized. They should be placed in distributor pipes only in making necessary vertical or horizontal changes in pipe direction

2.1.9 Easements

- (a) General requirements: Water mains shall be located within public right-of-way wherever feasible. When placement in right-of-way is not possible, water mains may be installed on private property only where the developer owns the property or has obtained a recorded, dedicated water easement from the property owner.

The easement shall provide sufficient width to accommodate the water main maintenance activities, and future replacement. The City of Maryville WSD requires a minimum width of 20 feet for water easements, unless a greater width is deemed necessary by WSD Engineering based on main depth, maintenance access or other design factors.

Easement alignment shall be reviewed and approved by WSD Engineering to ensure compliance with design standards, maintenance access, and long-term system integrity.

- (b) New development: Easements shall be identified on the recorded plat.
- (c) Cross-lot easements: When a water main must cross private property to provide service to another property, the developer shall obtain a dedicated water easement from each affected property owner. The easement must be recorded prior to construction and meet all requirements in this section.

General utility, drainage & utility, or other non-specific easements shall not be used for water main installation unless the recorded easement document explicitly grants water rights and allows access for construction, operation, maintenance, and replacement.

- (d) Restrictions: No permanent in-ground structures (including buildings, retaining walls, pools, or footings) shall be installed within water easements. Surface features such as fences, landscaping, and pavement may be installed at the owner's risk, provided they do not restrict access for maintenance and repair. Any surface features damaged or removed during water main work shall be the owner's responsibility to repair or replace.

2.2 DETAILS OF DESIGN AND CONSTRUCTION OF DISTRIBUTOR MAINS

2.2.1 Pipe Support

Adequate support shall be provided for all pipes.

2.2.2 Pipe Bedding

A continuous and uniform bedding shall be provided in the trench for all buried pipe. Bedding shall be accordance with manufacturer's recommendations.

2.2.3 Rock Excavation

Rock shall be removed for a depth of at least 6 inches below the bottom of the pipe.

2.2.4 Pipe Cover

(a) All distributor mains shall be provided with sufficient earth or other suitable cover to prevent freezing and to provide protection to the pipe. The cover shall not be less than 36-inches for 6-inch and 8-inch pipe, 42-inches for 10-inch and 12-inch pipe and 48-inches for pipe larger than 12-inch. The cover depth shall be measured from the top of the pipe to either the existing or proposed ground elevation, whichever is lower. The listed cover depths shall be maintained throughout the construction project.

(b) Water lines constructed parallel to roadways shall be installed using the existing or proposed road elevation, whichever is lower, to meet depth requirements. This will ensure sufficient cover over the water line for future driveway cuts or road widenings.

2.2.5 Pipe Alignment

Alignment of pipe shall be installed as true as practical. When it becomes necessary to deflect pipe alignment, such deflection shall be limited to the deflection recommended by the manufacturer.

2.2.6 Hydrostatic Tests

(a) Pressure and leakage tests for ductile iron pipe shall be performed in accordance with AWWA Standard C-600.

(b) The procedure for ductile iron pipe is generally described below:

1. The test pressure of the installed pipe shall be a minimum of 150 psi or 1.5 times the working pressure, whichever is greater.
2. Allowable leakage shall be no greater than as calculated in the following formula:

(c) $L = SD (\sqrt{P}) / 133,200$, where L is allowable leakage in gallons per hour, S is length of test section in feet, D is the pipe diameter in inches, and P is the average test pressure in psi. Pressure shall not fluctuate more than 5 psi.

2.2.7 Disinfection of New Distributor Mains

The specifications shall include detailed procedures for the adequate flushing, disinfection, and bacteriological testing of all new mains. Disinfection as described in current AWWA Standard C-651 will be accepted.

2.2.8 Disinfection When Cutting Into or Repairing Existing Distributor Mains

- (a) Shall be performed when mains are wholly or partially dewatered.
- (b) Shall follow current AWWA Standard C-651 procedures including trench treatment, swabbing with hypochlorite solution, flushing and/or slug chlorination as appropriate.
- (c) Bacteriological testing should be done after repairs are complete, but the water line may be returned to service prior to completion of testing to minimize the time users are out of water.
- (d) Leaks or breaks that are repaired with clamping devices while mains remain full of water under pressure require no disinfection.

2.2.9 Means of Detecting PVC Pipe

When existing PVC pipe is repaired, the existing minimum size 12 gauge copper wire shall be maintained.

2.2.10 Separation of Water Mains and Sewers

- (a) General: The following factors should be considered in providing adequate separation:
 - 1. Materials and type of joints for water and sewer pipes.
 - 2. Soil conditions.
 - 3. Service and branch connections into the water main and sewer line.
 - 4. Compensating variations in the horizontal and vertical separations.
 - 5. Space for repair and alterations of water and sewer pipes.
 - 6. Offsetting of pipes around manholes.
 - 7. Water mains and sanitary or storm sewers shall not be laid in the same trench.
- (b) Parallel Installation:
 - 1. Normal conditions - Water mains shall be laid at least 10-feet horizontally from any sanitary sewer, storm sewer or sewer manhole, whenever possible; the distance shall be measured edge-to-edge of the pipe.
 - 2. Unusual conditions - When local conditions prevent a horizontal separation of 10-feet, a water main may be laid closer to a storm or sanitary sewer provided that:
 - i. The bottom of the water main is at least 18 inches above the top of the sewer;
 - ii. Where this vertical separation cannot be obtained, the sewer shall be constructed of materials and with joints that are equivalent to water main

standards of construction and shall be pressure tested to assure water tightness prior to backfilling.

(c) Crossings:

1. Normal conditions - water mains crossing house sewers, storm sewers, or sanitary sewers will be laid to provide a separation of at least 18 inches between the bottom of the water main and the top of the sewer, whenever possible.
2. Unusual conditions - When local conditions prevent a vertical separation as described under Section 2.2.10(c)1. of these Standards, the following shall be used:
 - i. Sewers passing over or under water mains should be constructed of the materials described in Section 2.2.10(b)2.ii. of these Standards.
 - ii. Water mains passing under sewers shall, in addition, be protected by providing a vertical separation of at least 18-inches between the bottom of the sewer and the top of the water main; adequate structural support for the sewers to prevent excessive deflection of joints and settling on and breaking the water mains; that the length of water pipe be centered at the point of crossing so that the joints will be equidistant as far as possible from the sewer. Both the sewer and the water main shall be constructed of water pipe and tested in accordance with Section 2.2.6 of these Standards.

(d) Sewer Manholes: No water pipe shall pass through or come into contact with any part of a sewer line or sewer manhole.

2.2.11 Surface Water Crossings

Surface water crossings, both under and over water, present special problems which should be discussed with the Maryville Water and Sewer Department; the Tennessee Department of Environment and Conservation, Division of Water Resources; and the U.S. Army Corps of Engineers before plans are prepared.

(a) Above Water Crossings - the pipe shall be:

1. Adequately supported;
2. Protected from damage and freezing;
3. Accessible for repairs and replacement.

(b) When Crossing Water Courses which are greater than 15-feet in width:

1. The pipe shall be of special construction, having flexible, watertight joints;

2. Valves shall be provided at both ends of the water crossing so that the section can be isolated for test or repair, the valves shall be easily accessible and not subject to flooding;
3. Sampling taps should be available at each end of the crossing;
4. Permanent taps should be made for testing and locating leaks.

2.2.12 Cross Connections

- (a) There shall be no connections or potential connections between any part of the potable water system and any other environment containing other substances in a manner that, under any circumstances would allow such substances to enter the potable water system.
- (b) When an actual or potential hazard to the public water system exists, approval must be obtained from the City prior to construction. Such potential hazard include, but are not limited to, lawn irrigation systems, car wash mechanical rooms, commercial or coin laundries, photo processing labs, funeral homes, and fire protection systems. Proposed or existing physical connections such as these must be protected by an approved backflow protective device as promulgated in Title 18, Chapter 3 of the Municipal Code.
- (c) Neither gases, liquids, or solids, such as chemicals, waste products, steam, water from other sources (potable or non-potable), or any matter that may change the color or add odor to the water shall be returned to the potable water system.
- (d) In the case of premises on which any industrial fluids or any other objectionable substances are handled in such a fashion as to create an actual or potential hazard to the public water system, the City shall require the installation of an approved backflow prevention assembly in the customer service line. The approved backflow prevention assembly shall be appropriate to the degree of hazard.

2.2.13 Water Services and Plumbing

Water services and plumbing shall conform to the current International Plumbing Code that has been adopted by the City of Maryville.

2.2.14 Relations to Other Utilities

In no instance shall any other utility occupy the same trench with a water line.

2.3 PRODUCTS

2.3.1 General

- (a) Used water main pipe that meet these Standards may be used again, after the pipe has been thoroughly cleaned and restored practically to its original condition.

- (b) Packing and jointing materials used in the joints of pipe shall meet the Standards of the American Water Works Association. Either mechanical joints or slip-on joints with rubber gaskets are required for pipe.
- (c) Pipe and all accessory fittings, boxes, etc., shall be made in America where possible unless approval is obtained from the Water and Sewer Department for the use of a product that is not made in America. This requirement shall be construed in a manner which does not violate the North American Free Trade Agreement, any amendments thereto, or any other free trade or other laws.

2.3.2 Pipe

- (a) Pipe shall be of ductile iron meeting the latest requirements of AWWA Standard C-151, minimum Class 51 thickness, cement-mortar lined meeting the latest requirements of AWWA Standard C-110, with either mechanical joints or slip-on joints with rubber gaskets. Ductile iron pipe shall be either American Cast Iron, U.S. Pipe, Griffin, McWane Pipe, or approved equal.
- (b) When repairing existing PVC pipe two inches in diameter, the pipe shall be SDR-21, Class 200 pressure rated. The pipe must meet the requirements set forth in ASTM Standard D-2241 for 2-inch through 12-inch pipe designated SDR-21. The pipe must bear the National Sanitation Foundation Testing Laboratories, Inc. seal of approval for potable water or an approved equal.
- (c) Pipe shall be bell-end type.
- (d) Gaskets and lubricants intended for use during repair of existing PVC pipe shall be made from materials that are compatible with the plastic material and with each other when used together, but will not support the growth of bacteria and will not adversely affect the potable qualities of the water that is to be transported. Gaskets shall be the elastomeric type and shall be manufactured to conform with the requirements of ASTM F477.
- (e) Solvent cemented joints in the field are not permitted for repair of existing PVC pipe.
- (f) Pipe lengths shall be no greater than 20-feet.

2.3.3 Tees, Crosses and Bends

- (a) Tees, crosses, and bends for use with ductile iron pipe shall be cement-mortar lined, all mechanical joint.
- (b) Tees, crosses, and bends for use with ductile iron pipe shall be either 250 psi pressure rating cast iron meeting the latest requirements of AWWA Standard C-110 or 350 psi pressure rating ductile iron meeting the latest requirements of AWWA Standard C-153.
- (c) Bends for use in repairing existing 2-inch PVC pipe shall be bell-type, factory welded and shall meet the requirements for bells of pipe as set forth in ASTM Standard D-2241 for 2-inch through 12-inch pipe designated SDR-21.

- (d) Mechanical joint and plain end tees, crosses, or bends shall be manufactured domestically.
- (e) Mechanical joint locked hydrant tees or tapping tees may be permitted.

2.3.4 Reducers

- (a) Reducers for use with ductile iron pipe shall be cement mortar lined mechanical joint.
- (b) Reducers for use with ductile iron pipe shall be either 250 psi rating cast iron meeting the latest requirements of AWWA Standard C-110 or 350 psi rating ductile iron meeting the latest requirements of AWWA Standard C-153.
- (c) Mechanical joint and plain end reducers shall be manufactured domestically.
- (d) Repair of existing reducers for transition from ductile iron pipe to 2-inch PVC pipe shall be accomplished by use of a mechanical joint plug which has been provided with a 2-inch tap. A 2-inch bell and 2-inch NPT PVC transition fitting meeting the requirements as set forth in ASTM Standard D-2241 for 2-inch through 12-inch pipe designated SDR-21 connected to the tapped plug will effect an approved reduction. The 2-inch connection shall be made as shown on the Water Standard Detail Drawing.

2.3.5 Caps and Plugs

- (a) Caps and plugs for use with ductile iron pipe shall be mechanical joint except for slip-on type plugs which shall be restrained type, with cast lugs and furnished with a minimum of four restraining cap screws, and shall be manufactured domestically.
- (b) Mechanical joint caps and plugs shall be either 250 psi pressure rating cast iron meeting the latest requirements of AWWA Standard C-110, or 350 psi rating ductile iron meeting the latest requirements of AWWA Standard C-153.

2.3.6 Sleeves

- (a) Sleeves for use in connecting ductile iron pipe shall be mechanical joint and shall be manufactured domestically.
- (b) Sleeves shall be 250-psi pressure rating cast iron meeting the latest requirements of AWWA Standard C-110 or 350 psi pressure rating ductile iron meeting the latest AWWA Standard C-153.

2.3.7 Valves

- (a) Gate valves shall be mechanical joint, resilient-seat type, iron body, non-rising stem, "O"-ring, stem seal type, 2-inch square operating nut, open counterclockwise.
- (b) Gate valves shall meet the latest requirements of AWWA Standard C-509.
- (c) Gate valve pressure ratings shall be 200 psig.

- (d) Gate valves meeting the latest requirement of AWWA Standard C-509 shall be either Mueller Company, Model A2370; U.S. Pipe & Foundry Company, Model No. 5460; McWane Pipe and Foundry, Model F-6100; Clow Company, Model Number 5065; Waterous Company, Series 500; M & H Company, Model 3067-01; and American Cast Iron Company, American Darling, or any succeeding Model numbers, or approved equal.
- (e) Rubber-seated butterfly valves meeting the latest requirements of AWWA Standard C-504 will be acceptable for use on 10-inch or greater pipe. Rubber-seated butterfly valves shall be open counterclockwise, furnished with a 2-inch operating nut, mechanical joint type, Class 150-B.
- (f) Shop drawings of butterfly valves must be submitted to the Maryville Water and Sewer Department for approval.
- (g) Air release valves for use on water mains shall be Vent-Mat TM. Series RBX or approved equal. Each valve shall be designed/sized for its particular application. Reference the standard detail drawing. Valves are to be located outside of paved areas whenever possible and graded to assure positive drainage away from the valve installation. Rodent screens are required on all vent lines. Perforated lids may be substituted for the vent lines with City of Maryville Water and Sewer Department approval.

2.3.8 Valve Boxes

- (a) Valve boxes shall be the two-piece Buffalo screw type, 5 1/4-inch diameter shaft, capable of extending from valve stuffing box to ground surface, constructed of cast iron.
- (b) Valve box lids shall be provided with the word "WATER" embossed in the lid surface. Lids shall be compatible with the box lid receptacle.
- (c) The assembled valve box weight shall be approximately 60 pounds for 18-inch to 24-inch extension; 80 pounds for 24-inch to 36-inch extension; 90 pounds for 36-inch to 48-inch extension.
- (d) Shop drawings of valve boxes shall be submitted to the Water and Sewer Department for approval.
- (e) Valve boxes shall be manufactured domestically.

2.3.9 Blow-off Assemblies

Blow-off assemblies for dead-end 6-inch and greater pipe shall be accomplished by the installation of a 3-way fire hydrant meeting the requirements under Section 2.3.10 of these Standards. A gate valve meeting the requirements under Section 2.3.7 of these Standards with a valve box meeting the requirements under Section 2.3.8 of these Standards shall be located approximately three feet from the installed blow-off hydrant.

2.3.10 Fire Hydrants

- (a) Fire Hydrant shall conform to the latest requirements of AWWA Standard C-502.
- (b) Hydrant shall be equipped with two 2 1/2-inch hose outlet nozzles and one 4 1/2-inch pumper out nozzle.
- (c) Nozzle thread shall conform with NFPA No. 194 National Standard Fire Hose Coupling Screw Threads.
- (d) Size of hydrant main valve shall be 5 1/4-inch nominal diameter.
- (e) Size of hydrant inlet shall be 6-inch MJ with one set of MJ accessories.
- (f) Direction of rotation of the operating nut to open shall be counterclockwise.
- (g) The operating nut shall be pentagonal in shape. The pentagon shall measure 1 1/2-inches from point to flat at the base of the nut and 1-7/16 inches at the top, and the height of the nut shall not be less than one-inch.
- (h) Color of the finish paint above the ground line shall be Chrome Yellow or approved equal.
- (i) Hydrant shall be equipped with harnessing lugs.
- (j) Affidavit of Compliance shall be furnished for each hydrant.
- (k) Outlet nozzle-cap chains will not be required.
- (l) Hydrant shall be the Mueller Company, Centurion, Catalog No. A-423; American Cast Iron Pipe Company, American Darling, Catalog No. B-62-B; U.S. Pipe and Foundry Company, Metropolitan 250; M & H Company, Model 929 or 909, or any acceptable revisions of these models.

2.3.11 Restraint Measures

Thrust forces are created in a pipeline at changes in direction, tees, dead-ends or where changes in pipe size occur at reducers. Acceptable restraint measures include concrete thrust blocks, restrained joints, tie rods, or MEGALUG® restraint or approved equal. The details and dimensional data for concrete thrust blocks for 100-psi working pressure and soil bearings at 2000 pounds per square foot are given in the Water and Sewer Department Standard Drawings. For greater pressures or less soil bearing capacity, the quantities required should be calculated by the engineer. When tie rods or MEGALUG® restraint or approved equal are being used, thrust blocks shall be required.

When iron tie rods are being used, all exposed parts of such tie rods shall be given a final coating of bitumastic material for protection. Tie rods shall not be less than nominal 3/4 inch in diameter.

2.3.12 Tapping Sleeves and Valves

- (a) Tapping sleeves for mains 10" and smaller shall be cast iron with mechanical joint ends rated for 200 psi working pressure. End gaskets shall be duck-tipped type. Tapping sleeves shall be appropriately sized for use on O.D. pipe to be tapped. Tapping sleeves should be provided with tapped bosses for testing purposes. Side flange bolts and pipe shall be of corrosive resistant material. Tapping sleeve shall be U.S. Pipe Company, type 9 mechanical joint cast iron with non-corrosive bolts and nuts, duck-tipped gaskets or approved equal. Tapping sleeves for mains 12" and larger shall be stainless steel type
- (b) Tapping valves shall meet all requirements for gate valves under Section 2.3.7 of these Standards except flanged valve inlets Class 125 and mechanical joint outlets shall be provided. Tapping valve shall be U.S. Pipe Company, Hydragate No. 6860, or approved equal, and any succeeding catalog number for same.

2.3.13 Cut-in Sleeves and Valves

- (a) Cut-in sleeves shall be cast iron mechanical joint and plain end, class 200 pressure rated. Gaskets shall be duck-tipped. Mechanical joint gland should be provided with setscrews for bonding. Cut-in sleeves shall be Mueller Company H-842, or approved equal.
- (b) Cut-in valves shall be cast iron mechanical joint for use in ductile iron and cast iron pipe. Gaskets shall be duck-tipped. All other requirements for gate valves under Section 2.3.7 of these Standards shall be met. Cut-in valves shall be Mueller Company H-862, or approved equal.

2.3.14 Repair Sleeves and Bands

- (a) Repair sleeves used for repairing pipe may be either cast iron or ductile iron split type having appropriate pipe diameter range, mechanical joint ends, for 200 psi working pressure, furnished with two duck-tipped end gaskets. Split repair sleeves shall be Mueller Company, Catalog No. H-785, or approved equal.
- (b) Full circumferential stainless steel band-type couplings having appropriate pipe diameter range may be used only for repairing circumferential breaks in ductile iron pipe. Stainless steel band-type repair couplings must be capable of withstanding test pressures of 300 psi at a torque of 70 foot pounds for 5/8-inch bolts and 90 foot pounds for ¾-inch bolts; equipped with malleable iron lugs meeting ASTM A-47 Grade 32510, or ductile iron per ASTM A-536, Grade 60-40-18; with supporting side fingers, furnished with Grade 30 specially compounded rubber of new materials with ingredients to produce superior storage characteristics, performance and resistance to set after installation; bolts of high strength steel with heavy hexagon nuts meeting the latest requirements of AWWA Standard C-111.
- (c) Repair of 2-inch PVC pipe shall be accomplished by replacing damaged pipe using 2-inch PVC pipe and either PVC couplings meeting the requirements as set forth in ASTM Standard D-2241 for 2-inch through 12-inch pipe designated SDR-21, or

compression couplings of iron having galvanized protection with rubber gaskets having 5-inch minimum length. The repair of 2-inch PVC pipe shall include the repair or replacement of the detection wire.

2.3.15 Copper Tubing for Utility Service Lines

- (a) Copper tubing shall be seamless, type K soft tempered.
- (b) Copper tubing shall meet the requirements as set forth in ASTM Standard B-88 and AWWA Standard C-800 Appendix A for type K.

2.3.16 Corporation Stops

- (a) Corporation stops shall meet the latest requirements of AWWA Standard C-800.
- (b) Corporation stop inlets shall have AWWA threads, and the outlet shall have tapered threads conforming to ANSI B2.1. Outlets shall have male ends sufficient to accommodate copper flare coupling nuts.
- (c) Coupling nuts for use with flared type K copper service tubing shall meet the latest requirements of AWWA Standard C-800.
- (d) Corporation stops shall be limited to size 3/4-inch and 1-inch.
- (e) Corporation stops shall be Mueller Company, Catalog No. H-15000; The Ford Meter Box Company, Catalog No. F600, or approved equal, or any succeeding Catalog numbers.

2.3.17 Copper Service Unions

- (a) Unions for copper service tubing shall be the copper service thread, three-part type meeting the latest requirements of AWWA Standard C-800. The coupling nuts of the unions shall have copper service threads and shall meet the latest requirements of AWWA Standard C-800.
- (b) Copper service unions shall be used when coupling copper service tubing.

2.3.18 Tapped Saddles (For 2-inch PVC Pipe)

- (a) Saddles shall be used in connecting 3/4-inch and 1-inch service taps to 2-inch PVC Pipe.
- (b) Saddles shall be primarily copper and meet current SDWA requirements.
- (c) Saddles shall be double strap, two-part type. The upper and lower castings may be hinged together with a stainless steel pin. The screws connecting the upper and lower castings shall be of bronze. The lower casting shall be tapped to accept the screws. Saddles shall be designed to form a hydraulic seal between the pipe and a rubber gasket shall be furnished with each saddle. Outlets of saddles shall be tapped 3/4-inch or 1-inch AWWA thread for installation of a corporation stop.

- (d) Saddles shall be designated to be satisfactory for use with water up to 150 psi in accordance to Section 4.2, General Design under the latest requirements of AWWA Standard C-800.
- (e) Saddles shall be The Ford Meter Box Company, Inc., Catalog No. S70-203 for 3/4-inch AWWA thread; S70-204 for 1-inch AWWA thread; Mueller Co. for 3/4-inch or 1-inch AWWA thread; Hayes Pipe and Supply Co. for 3/4-inch or AWWA thread; or approved equal, or succeeding catalog numbers covering same.

2.3.19 Service Fittings

- (a) Adapters:
 - 1. Service fittings for use in 3/4-inch and 1-inch copper service tubing shall meet the latest requirements of AWWA Standard C-800.
 - 2. Adapters for use in 3/4-inch and 1-inch copper service tubing may be straight, quarter bend, or eight bend.
 - 3. Adapter inlets shall be flared copper except for corporation stop adapters.
 - 4. Adapters having 3/4-inch inlets shall have either male or female iron pipe thread outlets of either 3/4-inch or 1-inch size.
 - 5. Adapters having 1-inch inlets shall have either male or female iron pipe thread outlets of 1-inch.
 - 6. Corporation stop adapters shall have inlet threads compatible with old type corporation stop threads. Outlets of corporation stop adapters shall be copper flare with copper service threads. Gaskets used with corporation stop adapters shall be copper. Corporation stop adapters shall be used only for corporation stop sizes 5/8-inch, 3/4-inch, and 1-inch.
 - 7. Threaded pipe nipples for use in setting 2-inch and greater meters shall be of nominally 85% copper and 5% each of tin, lead, and zinc. Pipe nipple threads shall be NPT.
- (b) Tees for copper service pipe shall be flared copper to copper. Sizes shall be limited to 3/4-inch and 1-inch. Tees may have a combination of 3/4-inch and 1-inch branches and runs when deemed appropriate.
- (c) Brass plugs of either 5/8-inch, 3/4-inch, or 1-inch size having AWWA threads shall be used to plug taps where corporation stops have been removed from service.

2.3.20 Water Meters

Each meter shall have Automatic Meter Reading(AMR) capabilities and be compatible with the current Advanced Metering Infrastructure (AMI) system.

- (a) Water meter sizes 5/8-inch and 1-inch:
 - 1. Shall be the frost-proof type with cast iron bottom plate.
 - 2. Casing shall be of copper alloy containing not less than 75 percent copper.
 - 3. Register shall be the hermetically sealed magnetic type, straight reading, U.S. Gallons, with test hand or digital with test mode.
 - 4. Shall meet the latest requirements of AWWA Standard C-700.
 - 5. 5/8-inch meters shall be Badger meter, Inc. , Model 25; Hersey 430; or any succeeding model numbers, or approved equal.
 - 6. One-inch meters shall be Badger Meter, Inc. Recordall, Model 55 or any succeeding model numbers, or approved equal.

- (b) Water Meter size 2-inch:
 - 1. Shall be the compound, single register magnetic flanged type.
 - 2. Casings shall be of copper alloy containing not less than 75 percent copper and shall be furnished with tapped boss for field-testing purposes.
 - 3. Shall be furnished with oval companion flanges of copper alloy containing not less than 75 percent copper, gaskets, bolts, and nuts. Thickness of oval flanges shall be as required for Class 125 round flanges.
 - 4. Register shall be the hermetically sealed type, straight reading U.S. Gallons, with test hand.
 - 5. Shall meet the latest requirements of AWWA Standard C-702.
 - 6. A bypass may be required at the discretion of the Water and Sewer Department.
 - 7. Two-inch meters shall be Badger Meter, Inc., Recordall, Model 170; Rockwell International, Sensus; and any succeeding model numbers, or approved equal.

- (c) Shop drawings and performance data for water meters 2 inch size and larger shall be submitted to the Water and Sewer Department for approval. Flow demand, head loss, and range of user's expected flows will be considered by the Water and Sewer Department in making evaluation of such meters. All meters greater than 2-inch shall be installed with a bypass.

2.3.21 Meter Yokes (For 5/8-inch and 1-inch meters)

- (a) Yokes shall be the riser type for flared copper both ends.
- (b) The inlet shall have an all bronze inverted key angle valve close-coupled to the yoke piece.

- (c) The outlet shall have an all bronze ell close-coupled to the yoke piece.
- (d) The yoke piece shall be of cast iron, holding the inlet and outlet pipes, braced and correctly spaced.
- (e) Yoke angle valves and ells shall be connected to the yoke piece such that they can be rotated to connect to piping below.
- (f) A three-part expansion connection capable of being screwed on one end of the meter shall be furnished with each yoke. The expansion connection shall expand by turning a hand wheel to make watertight compression joints against rubber gaskets in the yoke ends.
- (g) Yokes shall be used for all 5/8-inch and 1-inch meter settings.
- (h) Yokes shall be The Ford Meter Box Company, Catalog No. 509, both ends flared copper for 5/8-inch meter settings and Catalog No. 512, both ends flared copper, for 1-inch meter settings, and Mueller Catalog No. H-5010 for 5/8-inch and 1-inch meter settings, or approved equal, and any succeeding catalog numbers.

2.3.22 Meter Boxes

- (a) Meter boxes for 5/8-inch meter settings for non-traffic condition shall be either the two-part rectangular thermoplastic type or the two-part rectangular concrete type. The cover shall be rectangular or thermoplastic or concrete having minimum dimensions of 10-inches by 15-inches furnished with a cast iron hinged reader lift having minimum dimensions of 4-inches by 7-inches provided with a keyhole for lifting.
- (b) Meter boxes for 1-inch meter settings for non-traffic conditions shall be the rectangular thermoplastic type or two-part rectangular concrete type having minimum inside dimensions of 16 1/2-inches by 22-inches. The cover shall be rectangular furnished with a cast iron hinged reader lift having minimum dimensions of 4-inches by 7-inches provided with a keyhole for lifting.
- (c) Meter boxes for 5/8-inch and 1-inch meter settings for traffic conditions shall be the two-part rectangular concrete type having minimum inside dimensions of 10-inches by 15-inches for 5/8-inch meter settings and 17-inches by 28-inches for 1-inch meter settings. The covers shall be of cast iron and shall be furnished with embossed tread markings and the word "WATER" on the top surface and shall be provided with a keyhole for lifting. Meter boxes and covers shall be capable of supporting minimum wheel loads of 16,000 pounds.
- (d) The minimum depth of combined two-part meter box sections for setting 5/8-inch meters shall be 18-inches and 1-in meters shall be 24 inches.
- (e) Meter box upper sections shall be designed with recesses for receiving covers. Covers and upper meter box sections shall be designed for easy cover removal and such that cover top surface when set will be flush with that of the upper meter box section rim.

- (f) Meter boxes for a 2-inch meter setting shall be the three-part rectangular concrete type having a combined minimum depth of 36 inches and minimum inside dimensions of 17 inches by 28 inches. Covers shall be the two-part cast iron type and shall be furnished with embossed tread markings and the word "WATER" on the top surface and shall be provided with a keyhole or other easy means for lifting cover sections. Meter boxes and covers shall be capable of supporting minimum wheel loads of 16,000 pounds. Alternate meter boxes for 2-inch meter setting shall be approved on an individual basis by the Water and Sewer Department.
- (g) Meters greater than 2-inch size shall be set in vaults. Drawings of the proposed vaults shall be submitted to the Water and Sewer Department for approval. Vaults in general shall be of poured in place reinforced concrete or of masonry construction having a minimum depth of 36 inches. The cover may be of reinforced concrete provided with an easy means for reading and removal of the meter and or appurtenances. Factory type covers will be considered by the Water and Sewer Department.
- (h) Meter boxes shall be as follows or approved equal:
 - 1. For 5/8-inch meter non-traffic settings - Ametek, Inc., standard thermoplastic 12-inch with 6-inch extension effecting 18 inches combined depth, thermoplastic cover with cast iron reader lift, or Brooks Products, Inc., Catalog No. 36, two-section, effecting 18 inches combined depth, concrete cover with cast iron reader lift.
 - 2. For 5/8-inch traffic settings - Brooks Products, Inc., Catalog No. 36T, (or any succeeding catalog numbers), two-section effecting 18 inches combined depth, with cast iron cover.
 - 3. For 1-inch meter non-traffic settings - Brooks Products, Inc., Catalog No. 65-H, (concrete) or 1914-18 (thermoplastic) (or any succeeding catalog numbers), two-section effecting 24 inches combined depth, concrete cover with cast iron reader lift.
 - 4. For 1-inch meter traffic settings - Brooks Products, Inc., Catalog No. 65T, (or any succeeding catalog numbers), two-section effecting 24 inches combined depth, all cast iron cover.
 - 5. For 2-inch meter settings - Brooks Products, Inc., Catalog No. 65T, (or any succeeding catalog numbers), three-section effecting 36 inches combined depth, two-part cast iron cover.

2.4 EXECUTION

- (a) All construction on the City of Maryville's water distribution system that is not performed by the Water and Sewer Department shall be executed by a person, firm, or corporation licensed to engage in contracting as set forth in the Tennessee

Contractors Licensing Act of 1976 (TCA 62-601). This requirement shall apply to all construction regardless of the amount of work involved.

- (b) Contractors shall hold the appropriate license designation for the work they are to perform.

2.4.1 Preparation

- (a) Precautions and permit to excavate:

1. Notify utility companies to locate existing facilities.
2. Abide by their requirements when repairing, replacing or disturbing existing facilities.
3. Prior to trench excavation being performed within any public right-of-way, including public alleys, a permit shall be obtained from the governing authority to perform such excavation. As a minimum, the trench backfill and street repair shall be made in accordance with the Maryville Land Development and Public Works Standards and Title 16, Chapter 2 of the Maryville Municipal Code.

- (b) Protect all vegetation and other features to remain.

- (c) The engineer shall stake in the field the alignment of the water line and the location of all fire hydrants, valves, bends, crosses, and other appurtenances identified on the plans. All survey points shall be protected.

- (d) Trench Excavation:

1. Perform in such a manner as to form a suitable trench in which to place the pipe and so as to cause the least inconvenience to the public.
2. To permit the proper installation of the pipe, allowing room for assembling joints and tamping backfill, the trench width at the crown of the pipe should be 2 feet plus the nominal diameter of the pipe. Unless approved by the Engineer, no trench less than 24-inches wide will be allowed.
3. Cut pavements along neat, straight lines with either a pavement breaker or pavement saw.
4. Trench depth shall be sufficient to provide a minimum cover in accordance with Section 2.2.4 of these Standards.
5. Align trench as shown on the plans and in accordance with Section 2.2.5 of the Standards.
6. Shape the bottom of the trench to provide uniform bearing of the pipe on undisturbed earth throughout its entire length. Dig bell holes to aid in securing uniform support of the pipe.

7. When unstable soil is encountered at the trench bottom, remove it to a depth required to assure support of the pipeline and backfill to the proper grade with AASHTO M-43, Size 3 or 4 course aggregate.
 8. Remove rock encountered in the trench excavation to a depth of 6 inches below the bottom of the pipe barrel, backfill with suitable earth, and compact to uniformly support the pipe.
- (e) Sheet piling, shoring and bracing: when necessary put in place and maintain sheet piling, bracing, etc., as may be required to support the sides of the excavation and to prevent movement. Remove all sheet piling, shoring and bracing after backfill has been placed to a depth of 18 inches over the pipeline.
 - (f) Before placing pipe in the trench, field inspect for cracks or other defects. Remove defective pipe from the construction site.
 - (g) Swab the interior of the pipe to remove all undesirable material.
 - (h) Prepare the bell end and remove undesirable material from the gasket and gasket recess.

2.4.2 Installing Distributor Pipes

- (a) Lay all pipe in accordance with Section 2.2.5 of these Standards.
- (b) After applying gasket lubricant, extreme care should be taken to keep the spigot end from contacting the ground.
- (c) As a minimum, the manufacturer's instructions for laying and joining pipe shall be followed.
- (d) Cut pipe for installing valves, fittings, etc., in a neat and workmanlike manner without damaging the pipe so as to leave a smooth end at right angles to the axis of the pipe. Hone the pipe as needed with suitable tools or equipment.
- (e) Locate water lines in relation to other piped utilities in accordance with Section 2.2.10 of these Standards.

2.4.3 Installing Appurtenances

- (a) Securely plug open ends of pipe at the close of each workday and during temporary discontinuance of pipe laying.
- (b) Set all valves, fittings, fire hydrants, and other specials in a neat workmanlike manner.
- (c) Use thrust blocks, restrained joints, and tie rods in accordance with Section 2.3.11 of these Standards.

- (d) Install fire hydrants to stand plumb with the pumper nozzle facing the street or in a direction as may be directed by WSD or the City of Maryville Fire Department.
- (e) Effect drainage of fire hydrants by using a minimum of 6 cubic feet of Size No. 2 or No. 3 crushed stone.

2.4.4 Installing Water Lines in Street, Highway, and Railroad Rights-of-Way

- (a) Permits as may be required for crossing streets, highways, and railroads and performing other work within their rights-of-way shall be obtained from the appropriate authorities.
- (b) As a minimum, boring and jacking methods shall be in accordance with the Maryville Land Development and Public Works Standards.

2.4.5 Water Line Pressure Tests

- (a) After the pipe has been laid, subject all newly laid pipe or any valved section thereof, to a hydrostatic pressure of at least 150 psi or 1.5 times the working pressure, whichever is greater.
- (b) Test pressure shall:
 - 1. Not exceed the pipe or thrust restraint design pressures.
 - 2. Be of at least 2-hour duration.
 - 3. Not vary by more than plus or minus 5 psi.
 - 4. Not exceed twice the rated pressure of closed valves or fire hydrants included in the test section.
 - 5. Not exceed the rated pressure of resilient seated butterfly valves.
- (c) Pressurization:
 - 1. WSD personnel will fill each valved section of pipe with water.
 - 2. Apply the specified test pressure, by means of a pump connected to the pipe, based on the elevation of the lowest point of the line or section under test, and correct to the elevation of the test gauge.
- (d) Air removal:
 - 1. Before applying the specified test pressure, expel air completely from the pipe, valves, and hydrants.
 - 2. Install air release valves at all points where entrapment of air occurs.

3. After all the air has been expelled, close all air release valves and apply the test pressure.

(e) Examination:

1. Carefully examine all exposed pipe, fittings, valves, fire hydrants, and joints.
2. Repair or replace any damaged or defective pipe, fittings, valves or hydrants that are discovered with sound material and repeat the test until it is satisfactory to the Engineer.

2.4.6 Water Line Leakage Tests

(a) Concurrently conduct a leakage test with the pressure test.

(b) Leakage defined: The quantity of water that must be supplied into the newly laid pipe to maintain the specified test pressure after the air in the pipeline has been expelled and the pipe has been filled with water.

(c) Allowable leakage:

1. Allowable leakage shall be determined in accordance with Section 2.2.6 of these Standards.
2. When testing against closed metal-seated valves, an additional leakage per closed valve of 0.0078 gal/hr/in. of nominal size shall be allowed.
3. When hydrants are in the test section, test against the closed hydrant.

2.4.7 Acceptance of Installation

(a) If any test of pipe laid discloses leakage greater than that determined under Section 2.4.6 of these Standards, locate and repair the defective material until the leakage is equal to or less than the determined amount allowable.

(b) Repair all visible leaks regardless of the amount of leakage.

2.4.8 Cleaning and Disinfection of Water Lines

Thoroughly disinfect water lines in accordance with AWWA Standard C651 prior to placing in service.

1. Use chlorine disinfecting agent.
2. Allow water to escape from the ends of all lines to cause dispersion of the chlorine solution into all parts of the system.
3. Operate all valves and fire hydrants during the time disinfection is occurring.

4. Retain the chlorine solution in the lines for a period of 24 hours.
5. At the end of the 24-hour period, the residual chlorine must be a minimum of 25 ppm; otherwise, repeat the disinfection procedure again.
6. Upon completion of the disinfection procedure the heavily chlorinated water shall be flushed from the system on all main, branches, and hydrants until chlorine measurements show that the concentration in the water leaving the main is no higher than the distribution system.
7. After a minimum of 24 hours after the flushing of the line the first bacterial sample can be taken. After a minimum of 48 hours after the lines have been flushed the second bacterial sample can be taken.
8. After the second sample has passed, the line can be put into service.

2.4.9 Water Utility Service Line Connections

- (a) Where practical, tap water mains in the upper half of the pipe.
- (b) Maintain a distance of at least 24 inches between taps, measured along the axis of the water main.
- (c) Use tapped saddles for all taps on PVC mains.
- (d) Utility service line and meter setting sizes shall be at the discretion of the WSD.
- (e) Utility service lines shall be installed by the Water and Sewer Department from the water mains to the edges of the street right-of-way lines or to the edges of easements provided for such water mains.
- (f) Meter setting locations shall be at the discretion of the WSD. Meters 2-inch and larger shall be installed in a location free of vehicular traffic. Whenever possible, 5/8-inch and 1-inch meters should be set in a non-traffic area.

2.4.10 Annual Inspection

Approximately twelve (12) months following acceptance of the utility line, a follow-up inspection will be made to determine if any failures or deficiencies have occurred as a result of Contractor's or Developer's work and/or materials. Present at this inspection will be a representative of the City of Maryville Water and Sewer Department. The inspection shall be completed by the Water and Sewer Department representative, and a notice of the inspection and its findings shall be forwarded in writing to the Developer. The Developer will be responsible for correction of all failures or deficiencies of a mechanical nature and for failures or deficiencies caused by the work and/or materials of Developer and/or his agents which occur in the first year of operation. Any other failures or deficiencies which occur in the first year of operation will be the responsibility of the title owner of the affected property except that any failures or deficiencies on property dedicated to the City of Maryville by the Developer shall remain the responsibility of the

Developer throughout the one year warranty period. The Developer and/or property owner as appropriate, is further responsible for any additional damages done in completing the required repairs. Within ninety (90) days of notification of the findings of the one-year inspection, it is the responsibility of the Developer and/or property owner as appropriate to ensure that any and all changes and/or repairs have been completed. If the Developer is in compliance and no changes or repairs are needed either initially or within the ninety (90) day cure period, any bond posted shall be returned to the Developer within sixty (60) days of completion and acceptance of the work by the City following the one year inspection. If the Developer fails to complete any required repairs or changes and the ninety (90) day cure period passes after notice, any bond posted shall be paid immediately to the City of Maryville for the purpose of remedying any of the deficiencies and/or for completion of the project. Such funds shall remain the sole property of the City of Maryville, even to the extent that the actual costs of the work done are less than the amount of the bond forfeited to compensate the City of Maryville for the additional time and manpower needed to complete the work or to see that the work is completed. The Water and Sewer Department will oversee completion of the needed work at the expense of Developer and will charge Developer any overage incurred over the bond amount for the cost of the completed work. The Developer is responsible for such charges. If a bond has not been provided, the City may file suit or make other collection efforts against the Developer or any other appropriate parties immediately after the expiration of the ninety (90) day cure period for the cost of the work done or to be done to bring the property into compliance. The City shall receive from the Developer or any other appropriate party its reasonable litigation costs incurred as a result of Developer and/or other appropriate defendant failing to timely complete the required repairs identified in the one-year inspection. Such litigation costs include, but are not limited to, reasonable attorney's fees, court costs and deposition fees.

2.4.11 Bond Requirement

The Water and Sewer Department shall maintain a list of delinquent developers who are in default and have not in the past performed repairs required by the City of Maryville or the Water and Sewer Department after the ninety (90) day cure period following the inspection done at the one year warranty period. These developers shall be required to perform or pay for the required repair work and any and all prior projects for which the developer is responsible; otherwise, the developer will be required to post a performance bond acceptable to the City of Maryville to the Water and Sewer Department before commencement of any new projects involving the Water and Sewer Department. Such bond shall be in an amount equal to at least ten percent (10%) of the contracted cost of the water and sewer utility installation for the development. The performance bond shall be payable to the City of Maryville and shall be executed by a surety company duly authorized and qualified to do business in the State of Tennessee. This bond or cash deposit shall be conditioned upon the developer's completion of all requirements of the Water and Sewer Department as set forth in any contractual agreement with the City and in the Rules, Regulations, Rates and Policies for the City of Maryville, Water and Sewer Department pertaining to warranty work and required repairs to the water, sewer, and wastewater utility systems for the project.

2.5 STANDARDS FLEXIBILITY

2.5.1 Interpretations of these Standards and Design Criteria

Interpretations of these Standards and Design Criteria or the determination of any other Water and Sewer Department standards and design criteria not covered under these Standards shall be at the discretion of the Public Utility Director. The decision of the Public Utility Director shall be based on past practices, traditional policies, widely accepted professional principles and practices of the industry.

2.5.2 Right of Appeal

Any disagreement with the interpretations or determinations made by the Public Utility Director with respect to these Standards or any other standards not covered herein may be appealed to the City Manager.

2.6 WATER RULES, REGULATIONS, POLICIES

2.6.1 Application for Water Service

Persons desiring water connections shall make application to the City, in writing, upon such forms as shall be provided by the City. The application shall state fully the use to which the water is to be applied and that the customer will abide by the Rules, Rates and Charges of the City then in force, or which thereafter is adopted. The application shall be signed by the owner or tenant of the premises and shall state the location of the premises to be served, including street, street number, and lot number. In the event the owner of the premises desires to be billed rather than the tenant for metered water used, the owner shall make application in accordance with the provisions of the Rules, Rates and Charges within the corporate limit of the City of Maryville, if the premises to be served is new construction, the applicant shall show that a building and/or plumbing permit has been issued by the Building and/or Plumbing official of the City.

2.6.2 Service Connection and Meter Setting Charges

Water utility service lines will be installed and maintained from the main to the edge of the right-of-way or edge of easement. The meter setting will be installed and maintained by the City. The owner or tenant will install and maintain all pipes and fixtures of his premises.

The water meter setting shall be placed at a suitable location selected by the City. However, the City will strive to place the meter setting where the customer desires. When making application, the tenant and/or property owner shall pay the charges required in the Water and Wastewater Rate Schedule and Customer Service Policy, as may be amended from time to time. The size of the utility service line from the main to the meter and meter size shall be determined by the City.

2.6.3 Customers Not To Supply Water To Others

Customers shall not supply water or allow water to be transported to other premises without the consent of the City.

2.6.4 Deposits

Before service is supplied, a deposit must be made by the customer in the amount indicated in the Water and Wastewater Rate Schedule and Customer Service Policy, as may be amended from time to time.

2.6.5 Rates

The monthly rates and/or charges for metered water shall be in accordance with the current Water and Wastewater Rate schedule as may be amended from time to time.

2.6.6 Meters

- (a) General: Each customer will be supplied water through a separate meter. Where a building under one ownership has a number of apartments (or offices) under one roof and the owner desires that the City deal directly with the tenants, the owner will make application for each unit to be served individually. Upon receiving application to serve multiple units, each tenant shall be subject to all applicable provisions of these Rules, Regulations, Rates and Charges. All meters and meter settings shall be furnished, owned, and maintained by the WSD. Meters and meter settings must be accessible at all times and not covered with rubbish or material of any kind.

The WSD will adjust the grade of the meter box one time only upon completion of new construction without charge. Any additional required adjustment caused by the regrading of the customer's property will be made by WSD at the expense of the customer.

- (b) Irrigation meters:

1. Residential irrigation: Private residential irrigation meters are not permitted. Private irrigation systems shall be connected on the customer side of the domestic meter. Irrigation meters serving common residential green space shall be evaluated on a case-by-case basis by the WSD. When approved, the maximum meter size shall be 5/8-inch. Commercial irrigation: Requests for irrigation meters in conjunction with a domestic meter shall be evaluated on a case-by-case basis. When approved, a 5/8-inch irrigation meter shall be supplied.

2.6.7 Meter Reading and Billing

Meter reading and billing policies will be in accordance with current City of Maryville policies as located in the Customer Service Policy.

2.6.8 Relocation of Meters

All meter locations the WSD considers to be unsatisfactory may be moved to a more suitable location and reconnected to existing customer service line at the expense of the WSD. The WSD may discontinue furnishing water to any customer who refuses permission to the WSD for relocation of a meter in accordance with this regulation.

Should a customer consider their meter location unsatisfactory, a request for relocation may be made to the WSD. If feasible, the WSD will relocate the meter as requested. The customer will be billed for actual cost of relocation.

2.6.9 Meter Testing

Should a customer question the accuracy of his meter registration, he may request that his meter be tested. The customer may make this request either in writing or orally to the WSD. The customer has the option to be present while the meter is being tested. The charge for testing a meter is indicated in the Customer Service Policy, as amended from time to time.

If the meter tested is found to register in excess of any of the accuracy limits shown in Appendix III to the Standards for the Water and Sewer Department of the City of Maryville, an allowance shall be made by the City, and the service charge will be retained by the City. (For Standards for Testing Water Meters, see Appendix III).

2.6.10 Meter Turn On/Off

Water shall not be turned on or shut off at the meter by anyone except an authorized employee of the City. Customer should request this service through the City service connections. Corresponding fees will be in accordance with current Customer Service Policy.

2.6.11 Damage To Water Meter

If a City-owned water meter is damaged due to an act by the customer, through negligence or abuse, such customer shall be responsible for the repairs and/or replacement of same. The customer will be billed for the actual cost of repair or replacement, and such bills shall be paid within thirty (30) days from the date of mailing thereof. Otherwise, the amount of the unpaid bill will be added to the customer's utility bill.

2.6.12 Responsibility for Property of Customer

The City shall not assume responsibility for damages incurred by water delivered through the meter, such as broken water lines within the customer's plumbing, spigots, valves, etc., left open at the time meter was installed.

In high-pressure areas in the City distribution system, it shall be the customer's responsibility to install a pressure regulating valve on the customer service line and pressure and temperature pop-off valves on the water heater. Any damages sustained for water heater blow-off shall be the customer's liability.

2.6.13 Shut-off Valve

A water shut-off valve must be installed within the plumbing system of each dwelling.

2.6.14 Discontinuance of Service

The City's personnel may shut off the water meter serving the customer for the following reasons:

- (a) Non-payment of bills
- (b) Unsafe apparatus
- (c) Fraud and abuse
- (d) Non-compliance with these Rules, Regulations, Rates, and Charges or any other Policy of the City, including the cross connection and sewer use ordinances.

2.6.15 Private Fire Lines

Private fire lines or sprinkler lines will be installed by and at the expense of the customer, such construction to be made in accordance with the City specifications, standards, and codes. Such lines shall be owned and maintained within the ROW by the city and the remainder of the line by the customer and shall be used solely for the supply of water for fire protection.

Authorized City personnel shall have access to the customer's premises at all reasonable hours for the purpose of inspecting fire lines and/or sprinkler lines. The fire line and/or sprinkler line charges shall be as reflected in the Schedule of Water Rates and Charges as shown under Customer Service Policy.

2.6.16 Swimming Pools

Fire hydrants are not permitted to be used in filling swimming pools.

2.6.17 No Guarantee of Pressure and/or Supply

The WSD does not guarantee any fixed pressure or a continuous supply of water. In the event of breaks in mains, utility service lines, pumping machinery, reservoirs, or other equipment of the WSD, the water may be shut off without notice, and the WSD shall not be liable for damages which may arise there from. When a planned water shut-off occurs, WSD personnel shall attempt to notify the affected customers.

2.6.18 Fire Hydrants inside Corporate Limit

All fire hydrants inside the corporate limit of the City of Maryville shall be maintained by the WSD and the City of Maryville Fire Department shall be charged an annual amount per fire hydrant, as shown in the Schedule of Fees and other Charges. (See the Customer Service Policy Manual.)

It will be the responsibility of the Fire Department to maintain a flow schedule as well as routine painting and lubrication of all fire hydrants within the corporate limit. The Fire Department will notify the City before flow testing fire hydrants and shall furnish a monthly

log of each fire hydrant flow tested, along with the appropriate data required by the City. Fire hydrants shall be installed within the system at such locations as approved by the Fire Chief and Water and Sewer Department.

2.6.19 Fire Hydrants outside Corporate Limit

The City of Maryville may install fire hydrants outside the corporate limit where lines exist that will provide adequate fire flow. The fire hydrants will be installed at the expense of the customer and shall become the property of the City of Maryville.

The location, size and type of fire hydrants outside the corporate limit will be determined by Water and Sewer Department.

No person, other than authorized agents of the City, fire departments, or fire companies, shall take water from fire hydrants outside the corporate limit without the consent of the City. Fire departments and/or other fire-fighting agencies shall, at the end of each month after the use of fire hydrants, submit a report to the City of the location of the fire hydrant used and the estimated gallons of water utilized. The City will bill the fire company for the estimated amount of water used.

No water shall be taken from fire hydrants outside the corporate limit for any use other than for fire fighting purposes, except by City personnel, fire departments or other fire fighting agencies, unless prior permission has been granted by the City.

2.6.20 Fire Hydrants - Private ownership Prohibited

Effective February 26, 1987, installation of privately owned fire hydrants within the City limit is prohibited. Owners of fire hydrants installed prior to February 26, 1987 may elect to pay an annual inspection charge per hydrant as shown in the Schedule of Fees and Other Charges, or transfer ownership of fire hydrants and appurtenances along with the necessary dedicated easements to the City. (See the Customer Service Policy manual) However, this section shall not apply to any private fire system wherein all water usage is metered. (Resolution No. 88-30, adopted, 1988.)

2.6.21 Fire Hydrant meters

Requests for fire hydrant meters shall be made to the City of Maryville Water and Sewer Department. Such requests will be evaluated and considered on a case-by-case basis. Fire hydrant meters are not available for the following purposes:

1. Building construction where there is an existing water main - in this case, customer should apply for a permanent tap;
2. Irrigation purposes;
3. Filling of swimming pools.

2.6.22 Cross-Connections

Approved Backflow Protection devices shall be installed by the plumbing contractor in accordance with Chapter 3, Title 18, of the Maryville Municipal Code, as may be amended from time to time.

Approved Backflow Protection Assemblies will be located a minimum of two (2') feet plus the nominal diameter of the device above the finished floor surface. Maximum height above the finished floor level will not exceed six (6') feet. Clearance of the device(s) from a wall surface or any other obstruction will be a minimum of six (6") inches.

Devices will be positioned where discharge from relief port will not create undesirable conditions. An approved air-gap will separate the relief port from any drainage system. An approved strainer will be installed immediately upstream of the backflow device(s) shutoff valve.

Devices will be located in an area free from submergence or flood potential. Devices shall not be installed in a pit. Should devices be installed outside the facility, devices will be protected from freezing.

A gravity drainage system is required for relief port drainage on installation. Should drainage be connected to a sanitary sewer drain, provisions must be made to prevent any sewer gases from being released back through the drainage system.

2.6.23 Supply Of Steam Boilers

In no event shall a steam boiler be supplied directly from a water main of the City. There shall be a tank or other receptacle located between the boiler and the water main and such supply shall be taken directly from the water tank or receptacle.

2.6.24 Special Service

The City may issue permits for the use of water for building or construction purposes, or other temporary purposes, provided the applicant pays for tapping and installation and conforms to all other requirements of the City.

2.6.25 Extension of Water Mains

The extensions of water mains shall be made in accordance with and subject to the conditions as set forth in PART II, Section 2.8, of this document.

2.6.26 Responsibility for Damages Incurred To Customer's Water Line

Effective March 8, 1988, the Water and Sewer Department of the City of Maryville, shall not assume liability for damages incurred by a water customer of the Water and Sewer Department when said damages have resulted from the following actions:

(a) damages caused by defective operation condition of customer's plumbing system,

- (b) damages caused by a defective condition in the water system, unless the Water and Sewer Department receives actual or constructive notice of a defective condition.

That all claims resulting from negligent operation, negligent installation, or negligent repairs, and all claims arising out of sudden and unexpected emergency repair work, will be handled on a case by case basis within the scope of the Tennessee Municipal League Risk Management Pool policies, and within the scope of general law, including the Tennessee Municipal Tort Liability Act.

2.6.27 Abandonment of Water Mains

When an existing water main is to be abandoned as part of a development project, the method of abandonment shall be based on recommendations provided by a licensed geotechnical engineer and shall be subject to review and approval by WSD Engineering.

Water mains located within roadways shall be completely removed, and the trench shall be backfilled with clean Size No. 7 crushed stone. In greenways or open space areas, compacted clay may be used as backfill.

2.7 WATER RATES AND CHARGES

Rates, fees and other charges for the water distribution system will be in accordance with current City of Maryville fee schedule as located in the Customer Service Policy Manual. Fees not included in the above policies will be charged based on actual costs.

2.8 WATER MAIN EXTENSIONS

In addition to the following regulations, each proposed water extension shall be evaluated for acceptance or rejection. The merits of which an extension is evaluated shall include, but not be limited to, the following:

1. Cost of operations and maintenance of equipment;
2. Projected revenues from utility sales generated as a direct result of the extension;
3. Concerns with respect to the environment and/or ecology; and
4. Overall budget considerations.

In general, and insofar as possible, each extension should be economically viable and self-sustaining on its own with minimal impact on the utility ratepayers as a whole.

2.8.1 Extensions within Existing Developed Areas of the City

The City will extend water mains along accepted streets or easements in existing developed areas within the corporate limit of the City for applicants having property on such streets, rights-of-way, or easements. These extensions shall be made at the expense of the City.

2.8.2 Extensions within New Subdivisions in the City

All water mains required to be extended along accepted streets and/or rights-of-way adjacent to the property line of the land parcels on which there are new subdivisions, and within the new subdivision, shall be installed by and at the expense of the developer. Also, should the City determine that the design capacity of the line should be increased to allow the service of areas other than the development; the City will pay the difference between the cost (including installation) of the line sized for the development versus the cost of the main to serve the expanded area. The size of such larger mains shall be at the discretion of the City. The developer is also required to install all fire hydrants within new subdivisions in accordance with City regulations.

2.8.3 Extensions Outside City Limit

All proposed water main extensions outside the City of Maryville must be granted approval to proceed from the City prior to preparation of plans. The City reserves the right to reject any extensions.

All water main extensions outside the City of Maryville shall be installed by and at the expense of the developer from the end of the existing water main whether it is inside or outside the City limit. However, if the City determines that it is in the best interest of the City, it may install or have installed said extensions and charge the developer a lump sum fee which shall include all applicable connection fees and line extension construction costs. Also, should the City determine that the design capacity of the line should be increased to allow the service of areas other than the development; the City will pay the difference between the cost (including installation) of the line sized for the development versus the cost of the main to serve the expanded area. The size of such larger mains shall be at the discretion of the City.

2.8.4 Exception

The regulations governing the extension of water mains shall not limit the City from participating in the cost of water main extensions when the application warrants consideration due to high volume consumption or favorable return on investment.

2.9 CROSS CONNECTION ORDINANCE

Refer to Chapter 3 of Title 18 of the Maryville Municipal Code Regarding Cross Connections, Auxiliary Intakes, Bypasses and Interconnections.

PART III-

Septic Tank Effluent Pump Installation Guidelines and Specifications

3.0 DEFINITIONS

1. ACCEPTED STREET

A street or avenue located within the City of Maryville which has been accepted by the City for maintenance, or a road or highway located outside the City of Maryville which has been accepted by Blount County.

2. CITY

The City of Maryville, Tennessee

3. CROSS-CONNECTIONS

Any physical construction whereby the City's water supply is connected with any other water supply systems, whether public or private, or either inside or outside any building in such a manner that a flow of water into the City's water supply is possible, either through the manipulation of valves or because of ineffective check or back pressure valves, or any other arrangement.

4. CUSTOMER

Any person who receives water and/or wastewater services from the City either under an express or implied contract requiring such person to pay the City for such service.

5. DEVELOPER

Any person, firm or corporation, both public and private, engaged in the development of land, such as subdivisions and other land improvements.

6. DWELLING

Any single structure occupied by one or more persons for residential purposes.

7. EASEMENT

A legally dedicated right-of-way for the City to install water and/or sewer lines within specified boundaries.

8. EXISTING DEVELOPED AREA

A developed area within the corporate limit having streets, water and/or sewer lines and appurtenances which have been accepted for operation and maintenance by the City.

9. MULTIPLE UNIT DEVELOPMENT

Any multi-unit complex, such as apartments, small business, etc. on one single parcel.

10. NEW SUBDIVISION

A development of a tract or parcel of land having two or more lots and having dedicated streets which have not been accepted by the appropriate governing agency.

11. PERSON OR TENANT

Firms and corporations, as well as individuals.

12. PREMISES

Any structure or group of structures, including land, operated as a single business or enterprise.

13. STEP COLLECTION LINE

A system of interconnected pipes for the purposes of collection of sanitary sewer wastes from individual lots and residences for delivery to a Publicly Operated Treatment Works (POTW).

14. STEP RESIDENTIAL SERVICE

The system of pump, pump vault, control panel, piping, and related appurtenances that provide transport of sanitary sewer from the STEP tank to the connection to the City of Maryville STEP collection line.

15. UNIT

An individual part of a multiple unit development

NOTE:

Whenever the context shall admit or require words used herein in the singular shall include the plural; words used in the plural shall include the singular; words used in the masculine shall include the feminine; and words used in the feminine shall include the masculine. Whenever a specific product name or trademark is used, it is to be understood that an equal, approved by the City of Maryville Water and Sewer Department and the Engineer, may be substituted.

3.1 SPECIFICATIONS - SEPTIC TANKS**3.1.1. Onsite Septic Tanks and STEP Pumping Assemblies Compatibility**

All septic tanks shall be constructed to allow for the installation of a Septic Tank Effluent Pump (STEP) without field modification of the tank openings and be compatible with STEP pump systems

3.1.2. Septic Tank Specifications Material, Construction and Installation

This specification outlines requirements for concrete septic tanks for used with Septic Tank Effluent Pump (STEP) systems. When used for septic systems, the septic tank shall meet the Tennessee Department of Environment and Conservation, Division of Water Resources (Ground Water Protection Program) Standard 0400-48-01-.09 for septic tanks.

3.1.3. Material

(a) Concrete will be ready mixed with cement conforming to TYPE II standards. It will have cement content not less than six sacks per cubic yard with an aggregate size of 3/4". It will have a minimum compressive strength of 5,000 psi (28) days.

- (b) Reinforcing will be 6"x 6" x 10 gauge wire mesh centered in top, bottom, sides, ends and lids, with one inch of concrete cover. Additional top reinforcing shall be #3 rebar with 12" center length and 1" center width.
- (c) Sealant shall be 1" x 1" Butyl Rubber Mastic Sealant between lid and tank at the joint-line and shall run continuously.

3.1.4. Septic Tank

- (a) The septic tank shall be 1500 gallons in capacity with 12" freeboard. It will have the capability for 3 inlets with maximum pipe size of 4". The lid shall have a 16" round opening with grooves to accept the pump riser on the outlet end and the inspection riser on the inlet end.
- (b) The septic tank shall have 3" thick walls with a 4" thick bottom and top. The walls and bottom shall be poured monolithically. The septic tank baffle wall shall have five 4" holes 24" from the bottom of the tank and a 2" vent slot at top of the baffle.
- (c) The inlet tee will be for the contractor to furnish and install.
- (d) The tank inlet shall be furnished with a pipe entrance coupling using a flexible molded neoprene compound boot meeting the latest requirements of ASTM Standard C443 or a rubber boot meeting the latest requirements of ASTM Standard C923.
- (e) The pipe entrance couples shall be a Kor-N-Seal, Press Boot, or approved equal.
- (f) The septic tank shall have the manufacturer's initials and size on the outlet end.
- (g) The septic tank shall be tested at the manufacturer's facility prior to leaving the plant and certification of water tightness shall be provided to the owner and the servicing utility.

3.1.5. Installation, Bedding and Backfill

- (a) The septic tank hole shall not be more than 2 feet longer and wider than the tank with a maximum backfill cover of 30" and a minimum backfill of 6". There shall be a minimum of 6" of ½" or ¾" stone bedding when no rock outcroppings are found within the limits of the excavation. When rock outcroppings are present within the excavated hole, a minimum of 12 inches of stone bedding shall be required. City of Maryville inspectors shall be called and will inspect the septic tank hole excavation prior to placement of stone bedding. The stone bedding will be level.
- (b) After setting the septic tank in the hole it shall be vacuum tested for water-tightness, at the contractor's expense. The vacuum test will consist of a test pressure of 4 psi for 5 minutes, then backfilled after passage of leak test. The backfill must contain no rocks or stones larger than 2" in diameter, and the tank should be backfilled immediately after testing. Initially, a 12" layer of selected soil should be placed and compacted along the tank.
- (c) Do not install septic tank across path of vehicles or heavy equipment.

(d) Tank shall be by C.R. Barger & Sons, Harriman, TN or City of Maryville approved equal.

3.1.6. Inlet Risers & Lids

Inlet risers (required on all two compartment tanks and all tanks with 1500 gallon or greater capacity) shall be ribbed PVC as manufactured by ORENCO SYSTEMS, Inc. (OSI), or City of Maryville approved equal. Risers shall extend to the ground surface and shall have a minimum nominal diameter of 21 inches.

3.1.7. Outlet Risers

Shall be ribbed PVC as manufactured by OSI, or City of Maryville approved equal. Risers shall be at least 181, high, and shall have a minimum nominal diameter of 24" when used in a simplex vault or 30" when used in a duplex application and shall be factory-equipped with the following:

- (a) Rubber Grommets. Two 1" diameter grommets, one for the splice box and one for the pump discharge, installed as shown on the drawing.
- (b) Adhesive shall be two-part epoxy, one pint per riser, for bonding riser to tank. One quart for 30-inch diameter.

3.1.8. Lids

- (a) One lid shall be furnished with each riser. Lids shall be OSI Model FL-21g, FL-24g, or FL-30g, or City of Maryville approved equal, as appropriate. Lids shall be fiberglass with green non skid finish, and provided with urethane gasket, stainless steel bolts, and wrench. The riser and lid combination shall be able to support a 2500 lb. wheel load. (NOTE: This is not to imply that PVC risers are intended for traffic areas.)
- (b) Rigid closed-cell foam insulation of 2" thickness shall be bonded to the underside of the lid. The R value shall be no less than 10 per 2" increment.

3.1.9. Riser installation

Riser installation shall be accomplished according to the manufacturer's instructions.

3.2 STEP PUMPING ASSEMBLIES FOR SINGLE-FAMILY DWELLINGS

3.2.1. Step Pump Systems

All pumping systems shall be ORENCO SYSTEMS (OSI) High-Head Pumping or City of Maryville approved equal.

3.2.2. Step Pump Assemblies

The pump assembly or City of Maryville approved equal, shall be composed of:

- (a) Risers & Lids. As per section 3.1 above.

- (b) Screened pump vault shall be OSI Model x4S1254-24 Simplex Biotube screened pump vault or City of Maryville approved equal. The filter shall have a minimum effective screen area of no less than 22.5 square feet. The screened pump vault shall consist of a 12" diameter, 54" deep PVC vault with eight (8) 1½" diameter holes evenly spaced around the perimeter, located approximately 70% of minimum liquid level to allow for maximum sludge and scum accumulation before requiring pumping. Housed inside the PVC vault shall be the Biotube filter cartridge assembly consisting of ½" mesh polypropylene tubes. One 4" diameter flow inducer to accept the high-head effluent pump shall be mounted externally to the Biotube vault assembly. The external flow inducer shall be epoxied and riveted to the sidewall of the vault. The whole assembly shall have an encapsulated base with flow thru port at the bottom of the filter cartridge for the screened effluent to have access to the effluent pumps and corresponding external flow inducer.
- (c) Discharge hose and valve assemblies shall be OSI Model HV100BCX, 1" diameter, 150 psi PVC ball valve, PVC flex hose with working pressure rating of 100 psi, Schedule 40 PVC pipe, and a 12" length of PVC flex hose with fittings to be installed outside the riser or City of Maryville approved equal.
- (d) Mercury switch float assembly shall be OSI model MF3A or City of Maryville approved equal, with three mercury switch floats mounted on a PVC stem attached to the effluent screen. The floats must be adjustable without removing screened pump vault. The high alarm functions shall be preset as shown on the drawing. Each mercury switch float shall be secured with a nylon strain relief bushing. The "A" floats shall be UL or CSA-listed and shall be rated for 4.5 A @ 120V.
- (e) High-Head effluent pumps shall be OSI Model P100511-10 or City of Maryville approved equal, ½ Hp, 115V, single phase, 60 Hz, 2-wire motor, with a 10 foot long extra heavy duty (SO) electrical cord with ground to motor plug. Pump shall be UL and/or CSA listed as an effluent pump. Pump shall be provided with a non-prorated five (5) year warranty.
- (f) Electrical splice box shall be OSI model SB4 or City of Maryville approved equal, UL approved for wet locations, equipped with four (4) electrical cord grips and a 3/4-inch outlet fitting. Also included shall be UL-listed butt splice connectors.
- (g) Controls and alarms shall be OSI model Simplex S-1 or City of Maryville approved equal, and be listed per UL 508. Panels shall be field repairable without use of soldering irons or substantial disassembly. Control panels shall meet the following at a minimum:
1. Audible Alarm: Panel mount with a minimum of 80 db sound pressure at 24 inches as a warble tone.
 2. Visual Alarm: NEMA 4, 7/8-inch diameter, oil tight, with push-to-silence feature.
 3. Audio-Alarm Reset Relay: 115 V, automatic, with DIN rail mount socket base.
 4. Toggle Switch: 15 amp motor rated, single pole, double-throw with three positions: Manual (MAN), (OFF) and Automatic (AUTO).

5. Circuit Breaker Control Voltage Disconnect: Rated for 10 amps, OFF/ON switch, DIN rail mounting with thermal magnetic tripping characteristics.
6. Current-Limiting Circuit Breaker: Rated for 20 amps, OFF/ON switch, DIN rail mounting with thermal magnetic tripping characteristics.
7. Enclosure: NEMA 4X, fiberglass with stainless steel or non-metallic hinges, stainless steel screws and padlockable latch. 10" high x 8" wide x 5 1/8" deep.
8. Alarm Circuit: Wired separately from the pump circuit so that, if the pump internal overload switch or current-limiting circuit breaker is tripped, the alarm system remains functional.
9. Motor Start Contactor: rated for 24 FLA, single-phase, 60 Hz.
10. Elapsed Time Meter: 115VAC, 7-digit, nonresettable.
11. Pump Run Light.

3.2.3. Installation

- (a) All pumping systems shall be installed in accordance with the manufacturer's recommendations and the standard plans.
 1. Wiring shall be installed in accordance with the codes adopted by the City of Maryville or the local electric service provider.
 2. Wiring coding shall be as follows:
 - a. Red - Pump Off
 - b. Blue - Pump On
 - c. Yellow - High Level Alarm
 - d. Orange - Power alarm/control circuits - 10A circuit
 - e. Black - Power pump circuit
 - f. White - Power pump circuit
 - g. Green - Ground
- (b) The STEP installation shall be installed on a separate dedicated 30 amp house circuit.
- (c) All wiring shall be installed in buried conduit between the structure and the pump vault.
- (d) All wiring and plumbing installations including tank shall be inspected prior to burial.
- (e) Tank excavation shall be inspected prior to installation of bedding stone.
- (f) Force mains from the pump vault to the City of Maryville force main shall be installed in a manner to minimize local high spots in the line that might accumulate air. In the event that such high spots cannot be avoided air relief valve(s) may be required by the City of Maryville inspector.

- (g) Tank, tank risers and tank covers shall be installed so that access to the tank for inspection or repair is not blocked by structures or plantings.
- (h) STEP system installation shall be by individuals approved by the City of Maryville. Approval shall be based on successful completion of an STEP installation course conducted by the City of Maryville and demonstration of continued ability to perform installations in accordance with the Rules, Regulations, Rates and Polices of the City of Maryville.
- (i) Un-inspected sewer connections for STEP systems shall be treated as an illegal tap subject to fine and court citation.
- (j) WSD inspectors shall be present at initial pump start up and test.
- (k) Discharge piping from the pump vault to the connection with the City of Maryville force main shall be schedule 40 solid wall PVC pipe (200 PSI minimum pressure rating). NO CELLULAR CORE PIPE WILL BE ALLOWED.
- (l) A 12 gauge toning wire shall be taped to the discharge piping from the pump vault to the connection with the City of Maryville force main. Wire shall be visible in the pump vault and the City of Maryville connection vault with sufficient length present to allow for connections for location of the residential line.

3.2.4. Location

- (a) The pump control panel shall be mounted on the side of the house nearest the tank and pump. National Electric Code (NEC) requires that the control panel be located within 50 feet of and within sight of the pump.
- (b) The overflow of the access risers and STEP pump vault shall be located on the lot such that in the event of power outage or pump failure a high water condition will not back up water into the structure(s) served.

3.2.5. Commercial

Commercial installations of STEP systems shall be evaluated on a case by case basis by the City of Maryville Water and Sewer Department. STEP systems are primarily for the residential use. Commercial use shall be only with permission of the City of Maryville Water and Sewer Department.

3.3 ACCESS

The property owner shall furnish a signed, recorded, agreement running with the property, allowing the City of Maryville Water and Sewer Department or their delegated representative access to the STEP tank, pump vault, control panel and force main for inspection and operational evaluation.

3.4 REPAIR AND MAINTENANCE

The property owner shall be responsible for the maintenance and operation of the pump and force main from the property owner's pump to the City of Maryville connection to the force main. The City of Maryville shall make inspections as it deems necessary for the reliable operation of the force main and shall notify the property owner of any needed repairs or maintenance noted. Said inspections are supplemental in nature and are not intended to replace the normal responsibilities of the property owner to maintain and operate the pump and STEP system in accordance with the manufacturer's recommendations.

PART IV- Septic Tank Effluent Systems and Force Mains

4.0 DEFINITIONS

1. ACCEPTED STREET

A street or avenue located within the City of Maryville which has been accepted by the City for maintenance, or a road or highway located outside the City of Maryville which has been accepted by Blount County.

2. CITY

The City of Maryville, Tennessee

3. COST SUMMARY

Total estimated cost of project including all labor and materials costs. Costs will be a combination of material prices and the labor to install them. This is to be broken down to cost per foot of each size of pipe used, fire hydrants, appurtenances, and all miscellaneous items required to complete the construction.

4. CROSS-CONNECTIONS

Any physical construction whereby the City's water supply is connected with any other water supply systems, whether public or private, or either inside or outside any building in such a manner that a flow of water into the City's water supply is possible, either through the manipulation of valves or because of ineffective check or back pressure valves, or any other arrangement.

5. CUSTOMER

Any person who receives water and/or wastewater services from the City either under an express or implied contract requiring such person to pay the City for such service.

6. DEVELOPER

Any person, firm or corporation, both public and private, engaged in the development of land, such as subdivisions and other land improvements.

7. DWELLING

Any single structure occupied by one or more persons for residential purposes.

8. EASEMENT

A legally dedicated right-of-way for the City to install water and/or sewer lines within specified boundaries.

9. EXISTING DEVELOPED AREA

A developed area within the corporate limit having streets, water and/or sewer lines and appurtenances which have been accepted for operation and maintenance by the City.

10. MULTIPLE UNIT DEVELOPMENT

Any multi-unit complex, such as apartments, small business, etc. on one single parcel.

11. NEW SUBDIVISION

A development of a tract or parcel of land having two or more lots and having dedicated streets which have not been accepted by the appropriate governing agency.

12. PERSON OR TENANT

Firms and corporations, as well as individuals.

13. PREMISES

Any structure or group of structures, including land, operated as a single business or enterprise.

14. STEP COLLECTION LINE

A system of interconnected pipes for the purposes of collection of sanitary sewer wastes from individual lots and residences for delivery to a Publicly Operated Treatment Works (POTW).

15. STEP RESIDENTIAL SERVICE

The system of pump, pump vault, control panel, piping, and related appurtenances that provide transport of sanitary sewer from the STEP tank to the connection to the City of Maryville STEP collection line.

16. UNIT

An individual part of a multiple unit development

NOTE:

Whenever the context shall admit or require words used herein in the singular shall include the plural; words used in the plural shall include the singular; words used in the masculine shall include the feminine; and words used in the feminine shall include the masculine. Whenever a specific product name or trademark is used, it is to be understood that an equal, approved by the City of Maryville Water and Sewer Department and the Engineer, may be substituted.

4.1 SEPTIC TANK EFFLUENT PUMP SYSTEM APPLICABILITY

(a) The use of Septic Tank Effluent Pump (STEP) systems shall be confined to areas where:

1. In the opinion of the City of Maryville Water and Sewer (WSD) Department the extension of gravity sewers is not economically feasible.
2. There is an existing danger to public health due to failed or failing septic fields or other existing sanitary sewer treatment options.
3. The development is within the growth limits of the City of Maryville, or approval for service has been granted by Maryville City Council.
4. The use of STEP systems shall be primarily for residential sanitary sewer collection.
5. Isolated commercial establishments may be connected to STEP collection lines provided there is adequate capacity for the waste, taking into consideration the

ultimate load from residential customers, nature of the commercial waste, and growth of the area.

- (b) **SEPTIC TANK EFFLUENT PUMP SYSTEMS ARE NOT FOR USE IN NEW RESIDENTIAL OR COMMERCIAL DEVELOPMENTS.** New developments shall be served by conventional gravity systems and pump stations.
1. Commercial developments, unless advance plans have been made to provide for adequate capacity and chemical resistance within the collection systems lines and pumps.
 2. Individual residential STEP connections shall not be allowed to connect to existing force mains designed for use with grinder or solids handling pumps except as per section 4.7.9.

4.2 STEP COLLECTION DESIGN

4.2.1. Description of System Layout

The layout of extensions of the Maryville WSD System STEP collection force mains for STEP shall be by a branched system.

4.2.2. Pre design Conference

Before beginning a STEP system extension design, the design engineer should first confer with the City of Maryville in regard to the growth potential and density that may be expected in the general area of the extension being planned. A conference with the Maryville WSD's staff should follow to discuss the system standards and requirements as well as any problems related to the mains being extended.

4.2.3. Plans and Specifications Approval

- (a) Detailed plans and specifications for a proposed extension must be submitted along with the cost summary to the Maryville WSD for approval. Once approval has been obtained, the detailed plans and specifications must be submitted to the Tennessee Department of Environment & Conservation, Division of Water Pollution Control, for approval.
- (b) Each plan sheet shall bear an appropriate title block showing the name of the project, location, owner, engineer, date, scale in feet, true north where applicable, sheet number, revision date, and other information as may be required.

Each sheet shall contain a blank area at least 4 inches by 6 inches near the title block for imprinting the official "Approved for Construction" stamps of the Tennessee Department of Environment and Conservation and the Maryville WSD Engineering.

Plans shall be clear, legible and shall conform to the requirements of the Maryville WSD Standards.

(c) Upon completion of the project, the design engineer shall revise the detailed plans to reflect "As-Built" information and submit the revisions for review to the Maryville WSD. Upon acceptance of the "As Builts" the design engineer shall furnish WSD with one Mylar copy and one paper copy of the "As Built" drawings. DRAWINGS TO BE FURNISHED in Engineering format no larger than 22 inches x 34 inches. An electronic copy of the "As-Builts" shall be submitted on a compact disc (CD) in a format that can be edited into AutoCAD.

(d) Plans of STEP Mains:

A plan of existing and proposed STEP mains shall be submitted for projects involving additions to the existing STEP collection system. The plan shall show the location and size of all proposed STEP mains. A vicinity map must accompany all STEP main extension plans. A project layout map showing the entire project may also be required.

(e) Detailed Plans:

Plans should have a scale of not more than 100 feet to the inch and must show:

1. Locations of streets and STEP mains, size of mains, location and size of service lines, material and type of pipe.
2. All known existing structures both above and below ground which might interfere with the proposed construction, particularly water lines and gravity sewer lines, gas mains, storm drains, etc.
3. Stationing of the STEP line at 100 foot intervals and locations of all appurtenances by stationing.
4. No other utilities shall be drawn except for clarification or reference.
5. Sufficient detail shall be shown on the plans to allow for materials take off and location of lines in the field by a third party.
6. Profiles shall be drawn for all STEP force mains. Existing utility lines shall be field located whenever reasonable and the source of the utility locations noted on the plans. For all new construction of STEP lines, the relevant elevations of all pipelines and conflicting structures at utility crossings shall be shown.

(f) The Following Note(s) Must Be Included In The Plan Sets:

THE CONTRACTOR SHALL NOTIFY TENNESSEE ONE CALL AT LEAST 72 HOURS PRIOR TO ANY EXCAVATION FOR UTILITY LINE LOCATES. ANY DISCREPANCIES BETWEEN THE PLAN LOCATIONS AND THE ACTUAL FIELD LOCATIONS SHALL BE IMMEDIATELY COMMUNICATED TO THE DESIGN ENGINEER AND THE CITY OF MARYVILLE WATER AND SEWER DEPARTMENT.

4.2.4. Minimum STEP Force Main Pipe Size

- (a) The minimum size pipe shall be 2 inch diameter.

STEP force main extensions shall be SDR 17 Class 250 PVC pipe conforming to ASTM D 2241 PVC.

- (b) The size of pipe shall be justified by hydraulic analysis performed by an engineer who holds a valid license to practice in the State of Tennessee. STEP force mains shall be sized to accept the anticipated flow from the drainage area. Design shall be based on the use of the standard City of Maryville STEP pump for residential use.
- (c) All assumptions and any flow data used by the design engineer must be clearly documented and submitted with the hydraulic calculations. Hazen and Williams friction factor shall be applied for the type pipe being used, but in no case shall such friction factor be greater than 100.

4.2.5. Connections to Existing System

- (a) STEP lines within residential, commercial, and industrial developments shall be extended to the exterior property line(s) where it has been determined by the Maryville WSD that there will be a future need for their extension.
- (b) STEP lines within residential, commercial, and industrial developments shall be extended and connected to lines within the existing STEP collection system when required by the Maryville WSD.
- (c) Where dead end STEP collection lines occur they shall be provided with a flushing connection for use in flushing operations.

4.2.6. Ball and Gate Valves

- (a) Unless otherwise specified by the Director of the Maryville WSD, PVC gate valves or PVC ball valves shall be placed at all intersections of STEP collection system pipes. Valves shall be placed to allow for shut down of collection lines for repairs. Two valves shall be placed at each tee; valves shall be installed to allow for shut down of the collection lines with the minimum disruption of service when maintenance is required. Three valves shall be placed at each cross. Valves should be positioned in the pipeline approximately 3 feet distance from the tee or cross. In mainlines greater than 2 inches in diameter, a valve approved by the Maryville WSD shall be used. (Please reference Part II for standard water gate valves with epoxy linings, resilient seats, and mechanical joints with transition gaskets.) The use of glued connections and valves shall be allowed only in the customer service lines and connections.
- (b) Valves at no time shall be placed greater than 3,000 feet apart unless otherwise specified by the Public Utility Director. Additional valves may be required by the Maryville WSD for system operation and maintenance.

4.2.7. Bends

Bends in pipe shall be minimized. They should be placed in STEP collection pipes only in making necessary vertical or horizontal changes in pipe direction. All bends shall be thrust blocked in accordance with the standard details sheets.

4.3 DETAILS OF DESIGN AND CONSTRUCTION OF STEP COLLECTION SYSTEM MAINS

4.3.1. Pipe Support

Adequate support shall be provided for all pipes.

4.3.2. Pipe Bedding

A continuous and uniform bedding shall be provided in the trench for all buried pipe. Bedding shall be in accordance with manufacturers recommendations. For PVC pipe a two inch (2") layer of sand bedding shall be required below the pipe and above the crown of the pipe.

4.3.3. Rock Excavation

Stones found in the trench shall be removed to a depth of at least six inches below the bottom of the pipe.

4.3.4. Pipe Cover

(a) All STEP collection mains shall be provided with sufficient earth or other suitable cover to prevent freezing and to provide protection to the pipe. The cover shall not be less than 36 inches for all step lines. The cover depth shall be measured from the top of the pipe to either the existing or proposed ground elevation or from the subgrade of the adjoining street whichever is lower. The listed cover depths shall be maintained throughout the construction project.

(b) STEP collection mains constructed parallel to roadways shall be installed at a depth that will ensure sufficient cover over the STEP line for future driveway cuts or road widening.

4.3.5. Pipe Alignment

Alignment of pipe shall be installed as true as practical. When it becomes necessary to deflect pipe alignment, such deflection shall be limited to the deflection recommended by the manufacturer or to 5 degrees per pipe joint when using PVC force main, whichever is less.

4.3.6. Hydrostatic Tests

Pressure and leakage tests for PVC pipe shall be performed in accordance with the manufacturer's recommendations and the following tables and provisions or similar procedures which will insure equal or better results.

Pipelines of PVC material shall be tested at the pressures shown in the following table and the allowable leakage shall not exceed the requirements shown.

Pipe Size (inches)	Test Pressure (psig @ lowpoint)	Allowable leakage per 1000 feet (gals per hour)
2	150	0.18
4	150	0.37
6	150	0.55
8	150	0.72
10	150	0.90
12	150	1.08

Pressure shall be measured at the low point on each section of pipeline. The contractor shall furnish all gauges, meters, pumps and other equipment required and shall maintain said equipment in good condition for accurate testing.

Where leaks are visible at exposed joints and/or evident on the surface when joints are covered the leak shall be repaired regardless of the leakage rate shown by the leakage test.

Duration of the test shall be no less than two hours.

Lines which fail to meet leakage requirements shall be repaired and re tested until the test requirements are met.

All pipe, fittings, and other material found to be defective under test shall be removed and replaced at the Contractor's expense.

4.3.7. Means of Detecting PVC Pipe

When existing PVC pipe is repaired, the existing 12 gauge copper wire and warning tape shall be maintained along the entire length of the pipe. The ends of the wire shall terminate in a valve box or other acceptable location whereby detection equipment may be attached. New PVC pipe shall have 12 gauge toning wiring installed along the entire length of the pipe. The ends of the wire shall terminate in a valve box or other acceptable location whereby detection equipment may be attached. PVC or other GREEN plastic warning tape labeled "SEWER" shall be installed in the trench on top of the sand cover prior to backfilling with soil. Locate stations shall be placed at a maximum of 1,000 foot intervals.

4.3.8. Separation of Water Mains and STEP Sewers

(a) General:

The following factors should be considered in providing adequate separation:

1. Materials and type of joints for water and sewer pipes.
2. Soil conditions.
3. Service and branch connections into the water main and STEP collection line.

4. Compensating variations in the horizontal and vertical separations.
5. Space for repair and alterations of water and sewer pipes.
6. Offsetting of pipes around manholes.
7. Water mains and sanitary or storm sewers shall not be laid in the same trench.

(b) Parallel Installation:

1. Normal conditions - STEP collection lines shall be laid at least 10 feet horizontally from any water main; the distance shall be measured edge to edge.
2. Unusual conditions - When local conditions prevent a horizontal separation of 10 feet, a STEP collection main may be laid closer to a water main such that:
 - i. The bottom of the water main is at least 18 inches above the top of the STEP collection line;
 - ii. Where this vertical separation at crossings cannot be obtained, the STEP collection lines shall be constructed such that the crossing is centered in a full joint of pipe. STEP collection lines shall be pressure tested to assure water tightness prior to backfilling.
 - iii. At no time shall STEP collection system lines and water lines be installed in the same ditch.

(c) Crossings:

1. Normal conditions - STEP collection lines shall cross under water mains and will be laid to provide a separation of at least 18 inches between the bottom of the water main and the top of the sewer, whenever possible.
2. Unusual conditions - When local conditions prevent a vertical separation as described under 1 above, the following shall be used:

STEP force mains passing over water mains shall, in addition, be protected by providing a vertical separation of at least 18 inches between the bottom of the sewer and the top of the water main. Adequate structural support for the sewers to prevent excessive deflection of joints and settling on and breaking the water mains and the STEP collection systems lines. The lengths of water pipe and STEP collection pipe shall be centered at the point of crossing so that the joints will be equidistant on both sides of the crossing for both the water and sewer lines. Both the sewer and the water main shall be constructed and tested in accordance with the pressure testing requirements of the applicable section of these standards. (Note: adequate structural support shall be a minimum or compacted sand backfill to fully support both the water main and STEP force main at the point of crossing.)

(d) Sewer Manholes and STEP System Valve Boxes:

No water pipe shall pass through or come into contact with any part of a sewer line or sewer manhole.

4.3.9. Surface Water Crossings

Surface crossings, both under and over water, present special problems which should be discussed with the Maryville WSD; the Tennessee Department of Environment and Conservation, Division of Water Resources; and the U.S. Army Corps of Engineers before plans are prepared.

(a) Above Water Crossings - The pipe shall be:

1. Adequately supported;
2. Protected from damage and freezing;
3. Accessible for repairs and replacement;
4. Sleeved in ductile iron pipe with an approved interior coating that is resistant to corrosive chemicals present in STEP systems.

(b) When Crossing Water Courses which are greater than 15 feet in width:

1. The pipe shall be of special construction, having flexible, watertight joints;
2. Valves shall be provided at both ends of the water crossing so that the section can be isolated for test or repair, the valves shall be easily accessible and not subject to flooding;
3. Permanent taps should be made for testing and locating leaks.
4. Sleeved in ductile iron pipe with an approved interior coating that is resistant to corrosive chemicals present in STEP systems.

4.3.10. Cross Connections

There shall be no physical connection between the STEP collection system and any potable water system by means of any pipes, pumps, hydrants, or tanks whereby unsafe water or other contaminating materials may be discharged or drawn into the potable water system.

4.3.11. Customer STEP Pump Units and Connection to the STEP Collection System

Customer STEP pump installations and tie ins to the STEP collection systems shall conform to the International Plumbing Code, as may be revised and adopted from time to time by the City of Maryville and the Rules, Regulations, Rates and Policies of the Maryville Water and Sewer Department, Section III.

4.3.12. Relations to Other Utilities

In no instance shall any other utility occupy the same trench with STEP collection line.

4.3.13. Threaded Joints

Teflon tape or pipe joint compound shall be used for all threaded PVC joints.

4.4 PRODUCTS

4.4.1. General - Pipe

- (a) PVC pipe meeting the requirements of ASTM D 2241 (SDR 17) ASTM D 3139 for joints, and ASTM D 1784 for materials shall be used for all STEP collection lines. All plastic pipe shall be made from Type 1, Grade 1, Polyvinyl Chloride Plastic. Manufacturing tests shall conform with the industry standards for PVC water line. PVC PIPE SHALL BE WHITE IN COLOR OR OTHER WSD APPROVED COLOR. NO BLUE PVC PIPE SHALL BE USED IN STEP COLLECTION LINES.
- (b) Either mechanical joints or slip on joints with rubber gaskets are required for pipe. Glued joints meeting the recommendations and requirements of the manufacturer may be used for STEP collection lines less than 2 inches in diameter and for all residential lot connections.
- (c) Pipe and all accessory fittings, boxes, etc., shall be made in America where possible unless approval is obtained from the Maryville Water and Sewer Department for the use of a product that is not made in America. This requirement shall be construed in a manner which does not violate current trade agreement, any amendments thereto, or any other free trade or other laws.
- (d) When repairing existing PVC pipe two inches in diameter, the pipe shall be SDR 17, Class 250 pressure rated. The pipe must meet the requirements set forth in ASTM Standard D 2241 for 2 inch through 12 inch pipe designated SDR 17. The pipe must bear the National Sanitation Foundation Testing Laboratories, Inc. seal of approval for potable water or an approved equal.
- (e) Pipe shall be bell end type.
- (f) Gaskets and lubricants intended for use during repair of existing PVC pipe shall be made from materials that are compatible with the plastic material and with each other when used together, but will not support the growth of bacteria. Gaskets shall be the elastomeric type and shall be manufactured to conform with the requirements of ASTM F 477 and ASTM D 3139.
- (g) Solvent cemented joints in the field are not permitted for repair of existing mainline PVC pipe. Solvent cemented joints are allowed in customer service lines (laterals).
- (h) Pipe lengths shall be no greater than 20 feet.

4.4.2. Tees, Crosses and Bends

- (a) Tees, crosses, and bends shall be PVC fittings of the same dimension ratio and pressure rating as the STEP collection line on which they are installed.
- (b) Bends for use in construction or repairing existing 2 inch and larger PVC pipe shall be bell type, factory welded and shall meet the requirements for bells of pipe as set forth in ASTM Standard D 2241 for 2 inch through 12 inch pipe designated SDR 17.
- (c) Customer's service tees shall be bell type for the main line with a two inch female threaded connection for customer's connection lines.

4.4.3. Reducers

Reducers for use in construction or repairing existing 2inch and larger PVC pipe shall be bell type, factory welded and shall meet the requirements for bells of pipe as set forth in ASTM Standard D 2241 for 2 inch through 12 inch pipe designated SDR 17.

4.4.4. Caps and Plugs

Caps and plugs for use with PVC pipe shall be slip on type glued caps.

4.4.5. Sleeves

Sleeves shall meet the requirements of ASTM D 2241.

4.4.6. Valves

- (a) 4" and larger gate valves shall be mechanical joint, epoxy lined, resilient seat type, iron body, non rising stem, "O" ring stem seal type, 2 inch square operating nut, open counter clockwise.
- (b) Gate valves shall meet the latest requirements of AWWA Standard C 509.
- (c) Gate valve pressure ratings shall be 200 psig.
- (d) Gate valves meeting the latest requirement of AWWA Standard C 509 shall be either Mueller Company, Model A 2370; U.S. Pipe & Foundry Company, Model No. 5460; McWane Pipe and Foundry, Model F 6100; Clow Company, Model Number 5065; Waterous Company, Series 500; M & H Company, Model 3067 01; and American Cast Iron Company, American Darling, or any succeeding Model numbers, or approved equal.
- (e) Air release valves for use on STEP mains shall be Vent O Mat TM. Series RBX or approved equal. Each valve shall be designed/sized for its particular application. Reference the standard detail drawing. Valves are to be located outside of paved areas whenever possible and graded to assure positive drainage away from the valve installation. Rodent screens are required on all vent lines. Perforated lids may be substituted for the vent lines with the Maryville WSD's approval. At the discretion of the City of Maryville OSI air release assemblies may also be used.

- (f) Ball valves shall be used on lines less than 4" diameter. Ball valves shall be as manufactured by Spears 150 psi water service valves or approved equal.
- (g) Check valves for service laterals shall be 1¼" check valves as manufactured by E One corporation or approved equal.

4.4.7. Valve Boxes

- (a) Valve boxes shall be the two piece Buffalo screw type, 5¼" diameter shaft, capable of extending from valve stuffing box to ground surface, constructed of cast iron.
- (b) Valve box lids shall be provided with the word "SEWER" embossed in the lid surface. Lids shall be compatible with the box lid receptacle.
- (c) The assembled valve box weight shall be approximately 60 pounds for 18 inch to 24 inch extension; 80 pounds for 24 inch to 36 inch extension; 90 pounds for 36 inch to 48 inch extension.
- (d) Shop drawings of valve boxes shall be submitted to the Maryville WSD for approval.

4.4.8. Flushing Connections

Flushing connections shall be installed as per the standard detail sheets, see Appendix I, for STEP detail list.

4.4.9. Thrust Blocking

- (a) Thrust forces are created in a pipeline at changes in direction, tees, dead ends or where changes in pipe size occur at reducers. Acceptable restraint measures include concrete thrust blocks, restrained joints, and tie rods. The details and dimensional data for concrete thrust blocks for 100 psi working pressure and soil bearings of 2000 pounds per square foot are given in the Maryville WSD Standard Drawings. For greater pressures or less soil bearing capacity, the quantities required should be calculated by the engineer.
- (b) When iron tie rods are being used, all parts of such tie rods exposed to soil or weather shall be given a final coating of bituminous material for protection. Tie rods shall not be less than nominal ¾" in diameter.

4.4.10. Tapping Sleeves and Valves

- (a) Tapping sleeves shall be designed for use on PVC piping and approved by the Maryville WSD.
- (b) Tapping valves shall be designed for use on PVC piping and approved by the Maryville WSD.

4.4.11. Repair Fittings

Repair fittings shall be designed for use on pressure PVC force mains and approved by the Maryville WSD.

4.4.12. Repair Sleeves

(a) Repair of PVC pipe shall be accomplished by replacement of the damaged pipe or the installation stainless steel repair band and couplings. The repair of PVC pipe shall include the repair or replacement of the detection wire and warning tape.

(b) Repair of 2 inch PVC pipe shall be accomplished by replacing damaged pipe using 2 inch PVC pipe and either PVC couplings meeting the requirements as set forth in ASTM Standard D 2241 for 2 inch through 12 inch pipe designated SDR 17 or stainless steel repair bands and couplings. The repair of 2-inch PVC pipe shall include the repair or replacement of the detection wire and warning tape.

4.4.13. Service Connections

Service connections shall be in conformance with the standard drawings for STEP collection

4.4.14. Customer Service Connection Boxes

Customer service connection boxes shall be in conformance with the STEP collection system standard drawings.

4.4.15. Pipe Locating "Toning" Wire

Pipe locating "toning" wire shall be solid 12 gauge insulated copper wire.

4.4.16. Pipe Location "Warning Tape"

Pipe location "warning tape" shall be 2" minimum width green plastic warning tape reading "Sewer".

4.5 EXECUTION

(a) All construction on the City of Maryville's STEP collection system that is not performed by the Maryville WSD shall be executed by a person, firm, or corporation licensed to engage in contracting as set forth in the Tennessee Contractors Licensing Act of 1976 (TCA §62 601). This requirement shall apply to all construction regardless of the amount of work involved.

(b) Contractors shall hold the appropriate license designation for the work they are to perform and a valid City of Maryville or Blount County Business License.

4.5.1. Preparation

(a) Precautions and permit to excavate:

1. Notify utility companies to locate existing facilities.
 2. Abide by their requirements when repairing, replacing or disturbing existing facilities.
 3. Prior to trench excavation being performed within any public right of way, including public alleys, a permit shall be obtained from the governing authority to perform such excavation. As a minimum, the trench backfill and street repair shall be made in accordance with the Maryville Land Development and Public Works Standards.
- (b) Protect all vegetation and other features to remain.
- (c) The engineer shall stake in the field the alignment of the STEP line and the location of all valves, bends, crosses, and other appurtenances identified on the plans. All survey points shall be protected.
- (d) Trench Excavation:
1. Perform in such a manner as to form a suitable trench in which to place the pipe and so as to cause the least inconvenience to the public.
 2. Trench width shall be sufficient to permit the proper installation of the pipe, allowing room for assembling joints and tamping backfill, and thrust block installation.
 3. Cut pavements along neat, straight lines with a pavement saw.
 4. Trench depth shall be sufficient to provide a minimum cover in accordance with these Standards.
 5. Align trench as shown on the plans and in accordance with the Standards.
 6. Shape the crushed stone in the trench to provide uniform bearing of the pipe on the gravel bedding throughout its entire length. Dig bell holes to aid in securing uniform support of the pipe.
 7. When unstable soil is encountered at the trench bottom, remove it to a depth required to assure support of the pipeline and backfill to the proper grade with sand.
 8. Remove rock encountered in the trench excavation to a depth of 6 inches below the bottom of the pipe barrel, backfill with sand and compact to uniformly support the pipe.
- (e) Sheet piling, shoring and bracing: When necessary or when directed by the engineer, put in place and maintain sheet piling, bracing, etc., as may be required to support the sides of the excavation and to prevent movement. Remove all sheet piling, shoring, and bracing after backfill has been placed to a depth of 18 inches over the pipeline.

- (f) Before placing pipe in the trench, field inspect for cracks or other defects. Remove defective pipe from the construction site.
- (g) Swab the interior of the pipe to remove all undesirable material.
- (h) Prepare the bell end and remove undesirable material from the gasket and gasket recess.

4.5.2. Installing STEP Collection Pipes

- (a) Lay all pipe in a straight line on a general upward or downward grade and in accordance with these standards.
- (b) After applying gasket lubricant, extreme care should be taken to keep the spigot end from contacting the ground.
- (c) Bevel the pipe with suitable tools or equipment.
- (d) As a minimum, the manufacturer's instructions for laying and joining pipe shall be followed.
- (e) Cut pipe for installing valves, fittings, etc., in a neat and workmanlike manner without damaging the pipe so as to leave a smooth end at right angles to the axis of the pipe.
- (f) Locate STEP collection lines in relation to other piped utilities in accordance with these Standards.

4.5.3. Installing Appurtenances

- (a) Securely plug open ends of pipe at the close of each workday and during temporary discontinuance of pipe laying.
- (b) Set all valves, fittings, and other specials in a neat workmanlike manner.
- (c) Use thrust blocks, restrained joints, and tie rods in accordance with these Standards.
- (d) Close dead ends with caps or plugs meeting the requirements of these Standards.
- (e) Install air release valves as indicated on the plans and at other high points as directed by the Maryville WSD.
- (f) Install a concrete support pad under all valves. Pad to be 3,000 psi concrete minimum 28 day strength and poured against undisturbed soil.

4.5.4. Installing STEP Collection Lines in Street, Highway, and Railroad Rights of Way

- (a) Permits as may be required for crossing streets, highways, and railroads and performing other work within their rights of way shall be obtained from the appropriate authorities.

- (b) As a minimum, boring and jacking methods shall be in accordance with the Maryville Land Development and Public Works Standards.

4.5.5. STEP Collection System Pressure Tests

- (a) After the pipe has been laid, subject all newly laid pipe or any valved section thereof, to a hydrostatic pressure test as per these standards.
- (b) Air removal:
 - 1. Before applying the specified test pressure, expel air completely from the pipe and valves.
 - 2. Install air release valves at all points where entrapment of air occurs.
- (c) Examination:
 - 1. Carefully examine all exposed pipe, fittings, valves, and joints.
 - 2. Repair or replace any damaged or defective pipe, fittings, or valves that are discovered with sound material and repeat the test until it is satisfactory to the Maryville WSD.

4.5.6. STEP Collection System Leakage Tests

- (a) Concurrently conduct a leakage test with the pressure test as per the allowable leakage rates under these standards.
- (b) Leakage defined: The quantity of water that must be supplied into the newly laid pipe to maintain the specified test pressure after the air in the pipeline has been expelled and the pipe has been filled with water.

4.5.7. Acceptance of Installation

- (a) If any test of pipe laid discloses leakage greater than that determined under these Standards, locate and repair the defective material until the leakage is equal to or less than the determined amount allowable.
- (b) Repair all visible leaks regardless of the amount of leakage.

4.5.8. Cleaning of STEP Collection Lines

All STEP collection lines shall be flushed as necessary to remove any material that may have been deposited in the pipe during construction.

4.5.9. STEP Residential/Commercial Connections

- (a) Service connections shall be made by the installation of a tee. The tee shall have gaskets along the mainline and a 2 inch threaded connection for the service connection line.

- (b) Maintain a distance of at least 24 inches between taps, measured along the axis of the sewer force main.
- (c) Use tapped saddles for all taps on PVC mains when connections are added after the construction of the main. Tees and connections shall be left for each platted lot or proposed platted lot at the time of collection line construction.

4.5.10. Annual Inspection

Approximately twelve (12) months following acceptance of the utility line, a follow up inspection will be made to determine if any failures or deficiencies have occurred as a result of Contractor's or Developer's work and/or materials. Present at this inspection will be a representative of the Maryville WSD and the Developer or other appropriate parties. In the event that a representative of the Developer is not present, the inspection shall be completed by the Maryville WSD representative, and a notice of the inspection and its findings shall be forwarded in writing to the Developer. The Developer will be responsible for correction of all failures or deficiencies of a mechanical nature and for failures or deficiencies caused by the work and/or materials of Developer and/or his agents which occur in the first year of operation. Any other failures or deficiencies which occur in the first year of operation will be the responsibility of the title owner of the affected property except that any failures or deficiencies on property dedicated to the City of Maryville by the Developer shall remain the responsibility of the Developer throughout the one year warranty period. The Developer and/or property owner as appropriate, is further responsible for any additional damages done in completing the required repairs. Within ninety (90) days of notification of the findings of the one year inspection, it is the responsibility of the Developer and/or property owner as appropriate to ensure that any and all changes and/or repairs have been completed. If the Developer is in compliance and no changes or repairs are needed either initially or within the ninety (90) day cure period, any bond posted shall be returned to the Developer within sixty (60) days of completion and acceptance of the work by the City following the one year inspection. If the Developer fails to complete any required repairs or changes and the ninety (90) day cure period passes after notice, any bond posted shall be paid immediately to the City of Maryville for the purpose of remedying any of the deficiencies and/or for completion of the project. Such funds shall remain the sole property of the City of Maryville, even to the extent that the actual costs of the work done are less than the amount of the bond forfeited to compensate the City of Maryville for the additional time and manpower needed to complete the work or to see that the work is completed. The Maryville WSD will oversee completion of the needed work at the expense of Developer and will charge Developer any overage incurred over the bond amount for the cost of the completed work. The Developer is responsible for such charges. If a bond has not been provided, the City may file suit or make other collection efforts against the Developer or any other appropriate parties immediately after the expiration of the ninety (90) day cure period for the cost of the work done or to be done to bring the property into compliance. The City shall receive from the Developer or any other appropriate party its reasonable litigation costs incurred as a result of Developer and/or other appropriate defendant failing to timely complete the required repairs identified in the one year inspection. Such litigation costs include, but are not limited to, reasonable attorney's fees, court costs and deposition fees.

4.6 STANDARDS FLEXIBILITY

4.6.1. Interpretations of Standards and Design Criteria

Interpretations of these Standards and Design Criteria or the determination of any other Maryville WSD standards and design criteria not covered under these Standards shall be at the discretion of the Director of the Maryville WSD. The decision of the Director of the Maryville WSD shall be based on past practices, traditional policies, widely accepted professional principles and practices of the industry.

4.6.2. Right of Appeal

Any disagreement with the interpretations or determinations made by the Director of the WSD with respect to these Standards or any other standards not covered herein may be appealed to the City Manager.

4.7 SEPTIC TANK EFFLUENT PUMP RULES, REGULATIONS, POLICIES

4.7.1. Application for STEP Service

Persons desiring STEP connections shall make application to the City, in writing, upon such forms as shall be provided by the City. The application shall state fully the nature of the wastes to be collected that the customer will abide by the Rules, Rates and Charges of the City then in force, or which thereafter is adopted. The application shall be signed by the owner for new service and the owner or tenant of the premises for continuing service. The application shall state the location of the premises to be served, including street, street number, and lot number. In the event the owner of the premises desires to be billed rather than the tenant for metered sewer used, the owner shall make application in accordance with the provisions of the Rules, Rates and Charges.

Within the corporate limit of the City of Maryville, if the premises to be served is new construction, the applicant shall show that a building and/or plumbing permit has been issued by the Building and/or Plumbing official of the City.

4.7.2. Service Connection Charges

STEP collection system lines will be installed and maintained from the main to the customer connection at or near the right of way or edge of easement. The owner will install and maintain all pipes and fixtures for her/his premises. When making application, the appropriate tenant and/or property owner shall pay the charges required in the Sewer Rates and Charges Schedule listed in the Customer Service Policy Manual, as may be amended from time to time.

4.7.3. Customers Not to Sewer to Others

Customers shall not supply sewer service or allow other connections to their STEP collection system by or from other premises without the consent of the City.

4.7.4. Rates

The monthly rates and/or charges shall be in accordance with the Water and Sewer Rates and Charges Schedule as may be amended from time to time as shown in the Customer Service Policy Manual.

4.7.5. Billing

Billing shall be as per the Customer Service Policy Manual.

4.7.6. Responsibility for Property of Customer

The City shall not assume responsibility for damages incurred due to failure of the customers pump unit or check valve, or on lot plumbing.

4.7.7. Discontinuance of service

The City's personnel or authorized agents may shut off the water meter to the property that is connected to a STEP collection line serving the customer for the following reasons:

- (a) Non payment of bills
- (b) Unsafe apparatus
- (c) Fraud and abuse
- (d) Non compliance with these Rules, Regulations, Rates, and Charges or any other Policy of the City.
- (e) Any operating condition that is spilling sanitary sewer.

4.7.8. Extension of STEP Collection Mains

The extensions of sewer mains shall be made in accordance with and subject to the conditions as set forth in PART I of this document.

4.7.9. Force Main Usage Policy

- (a) GRAVITY SEWER LINES ARE REQUIRED WHEN FEASIBLE FOR SANITARY SEWER COLLECTION. THE USE OF PUMP STATIONS OR SMALL PUMPS SYSTEMS SIGNIFICANTLY INCREASES THE PERSONNEL, MAINTENANCE AND OPERATIONS REQUIREMENTS.

Sewer collection shall be evaluated and designed based on the following hierarchy of collection.

The first economically viable system shall be used.

1. Conventional Gravity Sewer collection systems.
2. Conventional Gravity Sewer collection systems with pump stations meeting the Maryville WSD requirements serving the entire subdivision or area.

3. Alternate sewer collection systems (STEP) using small force mains and septic tank effluent pump systems. STEP systems shall only be used when all of the conditions of 4.1 are met.

(b) Use of Existing Force Mains Inside City

Single pump stations shall be evaluated first for economic viability. If a single pump station is economically feasible then the STEP connections will not be allowed. If STEP systems are approved then, existing force mains inside the City of Maryville may be tapped for STEP pump connections after evaluation and approval by the Maryville WSD provided the following conditions are met:

1. Alternate means of providing gravity sewer have been evaluated and are not feasible.
2. The tap shall be for a STEP system tap using City of Maryville approved PUMPS and installation.
3. The existing force main shall have the capacity to allow the tap.
4. Taps shall be for a single lot or residence.
5. The residence to be served shall be a residence within the Corporate Limits of the City of Maryville.
6. All taps shall be made with a redundant check valve and ball valve at the property line as per the City of Maryville detail drawings. The property owner shall be responsible for all force lines from the residence to the redundant check valve at the City of Maryville connection.
7. The pump unit for the residence shall be able to exceed the hydraulic grade line of the existing force main.

(c) Use of Existing Force Mains Outside City

Existing force mains outside the City of Maryville have been designed for the use of large sewer pumping stations only. One lot connections to force mains that are designed to service existing large pump stations will not be allowed.

Where sufficient capacity exists or where pump stations can be sequenced to maintain capacity and not overload the force main, multiple large pump stations may be connected to the same force main. Such determination shall be made by the Maryville WSD. Input from the developer's engineer is encouraged but the decision to allow additional connections rests with the Maryville WSD.

APPENDIX I – DETAIL SHEETS

The standard detail drawing sheets are available on the City website or by contacting the WSD offices. Below is a list of the details and which sheet they are located on.

STANDARD DETAIL DRAWINGS WATER - SHEET 1 of 1

- General Utility Notes
- Water System Special Notes
- Water Valve Locations
- MLDI Water Line Trench
- Thrust Block
- Fire Hydrant Installation
- Water Line Combined Air/Vacuum Release Valve
- 2" PVC Water Line Tie-In

STANDARD DETAIL DRAWINGS SEWER - SHEET 1 of 2

- General Utility Notes
- Sanitary Sewer Special Notes
- Standard Pre-Cast Manhole
- Shallow Manhole
- Manhole Cover
- Manhole Frame – Standard and Watertight
- Drop Manhole
- Sewer Force Main – Combined Air/Vacuum Release Valve
- Sewer Service Assembly Location
- Sewer Service Location Symbol
- Trench Detail
- Trench Dam Detail

STANDARD DETAIL DRAWINGS SEWER - SHEET 2 of 2

- Grease Trap Detail – Traffic and Non-Traffic
- Oil/Grit Separator Detail - Traffic and Non-Traffic

STANDARD S.T.E.P. SEWER DETAILS--SHEET 1 OF 1

- S.T.E.P. Sewer Service Connection
- 2" Terminal Flushing Connection
- Air Release Assembly

- S.T.E.P. Dual Compartment
- S.T.E.P. Single Compartment
- Sizing and Testing

- NOTES:
- MH DIA. SHALL BE 48" FOR 18" AND LESSER DIA. PIPE AND 60" FOR 21" THRU 30" DIA.
 - 6X6 CLASS "A" CONC. PAD FOR MHs 12" DP. OR DEEPER. 6" MIN. TN. D.O.T. #67 OR #7 CRUSHED STONE FOR ALL MHs.
 - MH STEPS SHALL BE ALUMINUM & ALIGNED OVER INLET OR OUTLET.
 - USE PRE-CAST CONC. RINGS TO BRING GRADE WHERE NECESSARY.
 - PAINT OUTSIDE WALLS w/ (2) COATS OF BITUMINOUS PAINT APPLIED @ RIGHT ANGLES TO EA. OTHER IF SPECIFIED BY ENGINEER.
 - COAT OUTSIDE OF ALL JOINTS w/ BITUMINOUS ROOFING MATL.
 - FLEXIBLE COUPLING(S) REQ'D. WHEN INSTALLING M.H. AT AN EXISTING SEWER MAIN.

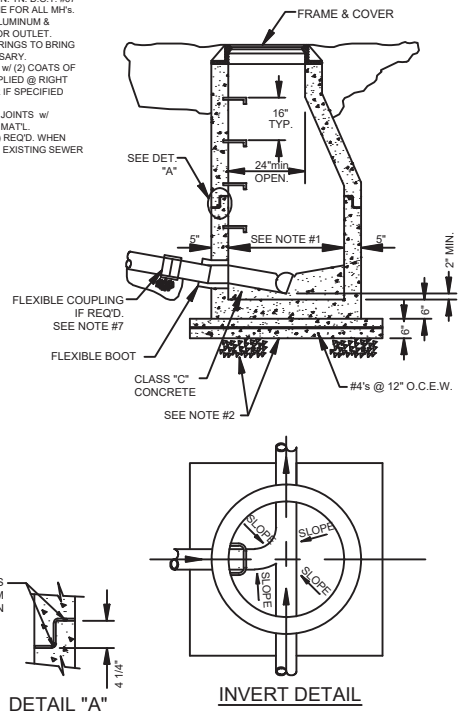

STANDARD PRE-CAST MANHOLE (MH-1) DETAIL

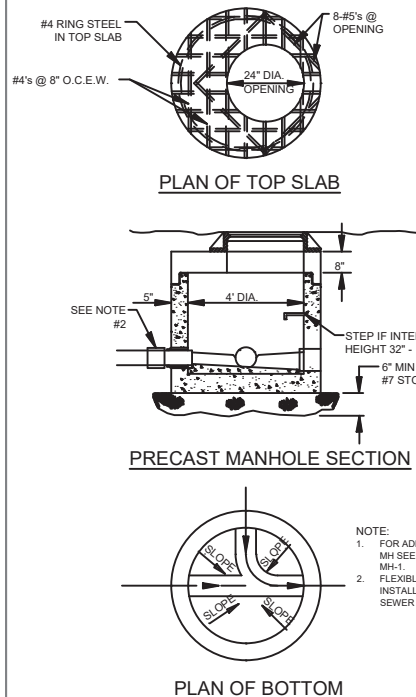

SHALLOW MANHOLE DETAIL

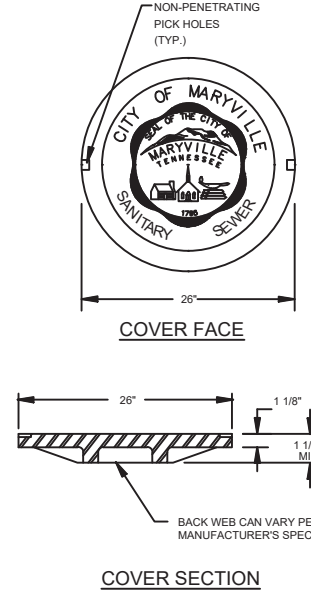

MANHOLE COVER DETAIL

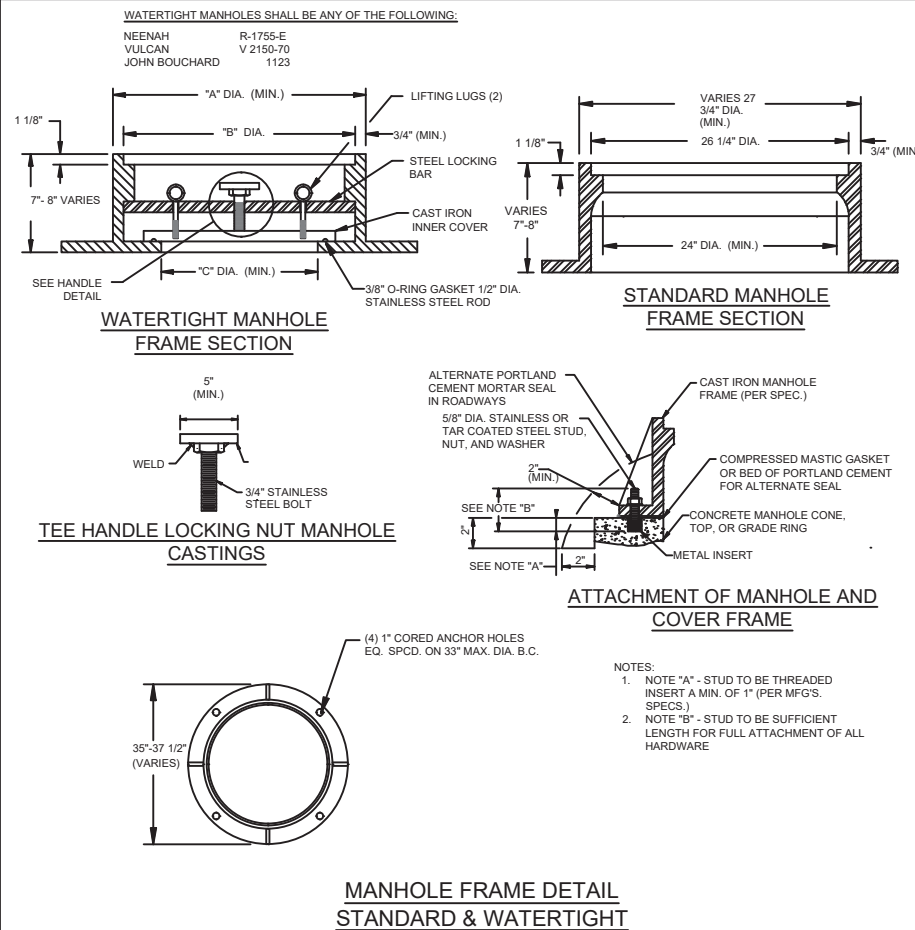

MANHOLE FRAME DETAIL STANDARD & WATERTIGHT

CITY OF MARYVILLE
GENERAL UTILITY NOTES:

ALL SEWER AND WATER EXTENSIONS SHALL BE BUILT IN ACCORDANCE WITH THE RULES, REGULATIONS, RATES, AND POLICIES OF THE CITY OF MARYVILLE WATER & SEWER DEPARTMENT, MARYVILLE, TENNESSEE WHICH ARE AVAILABLE FROM THE CITY OF MARYVILLE (COM) AT WWW.MARYVILLEGOV.COM. IN CASES OF CONFLICT, THE CITY OF MARYVILLE (COM) REGULATIONS SHALL RULE. IT SHALL BE THE DEVELOPERS AND CONTRACTORS RESPONSIBILITY TO OBTAIN AND FOLLOW THE REGULATIONS OF THE CITY OF MARYVILLE (COM). EASEMENTS SHALL EXIST AS PER THE SUBDIVISION PLAT OR RECORDED EASEMENTS DOCUMENTS. IF THE NECESSARY EASEMENTS ARE NOT IN PLACE, THE DEVELOPER SHALL OBTAIN AND FURNISH THE CITY OF MARYVILLE (COM) WITH EASEMENTS FOR THE PORTIONS OR UTILITY LINES THAT CROSS PRIVATE PROPERTY. THE EASEMENT DOCUMENTS SHALL BE REVIEWED BY THE CITY OF MARYVILLE (COM) FOR ACCEPTABILITY PRIOR TO SIGNATURES. ALL EASEMENT DOCUMENTS SHALL BE RECORDED PRIOR TO CONSTRUCTION OF THE UTILITY LINES. ALL WATER AND SEWER LINES SHALL BE LAID IN UNDISTURBED NATIVE SOIL WHENEVER PRACTICAL. AT THE JUNCTION OF ALL UNDISTURBED SOIL AND FILL SECTIONS OF THE PIPE TRENCH, THE BACKFILL MATERIAL SHALL BE DIVIDED BY AN IMPERMEABLE SECTION OF FILL (E.G. COMPACTED CLAY) AROUND THE INSTALLED PIPE TO PREVENT PIPING OF WATER THROUGH THE PIPE BEDDING. UTILITIES CROSSING UNDER OTHER UTILITIES SHALL BE BACK FILLED WITH COMPACTED WITH NO. 7 STONE TO THE SPRING LINE OF THE UPPER UTILITY TO PREVENT SETTLING OF THE UTILITY. ANY UTILITY TRENCH LOCATED WITHIN A ROADWAY OR PAVED AREA, INCLUDING PRIVATE DRIVES AND PARKING LOTS, SHALL BE COMPLETELY BACKFILLED WITH COMPACTED STONE IN ACCORDANCE WITH CITY OF MARYVILLE REQUIREMENTS. WATER AND SEWER SYSTEMS SHALL NOT BE GRANTED FINAL APPROVAL BY THE CITY OF MARYVILLE (COM) UNTIL "AS BUILT" DRAWINGS HAVE BEEN COMPLETED AND ARE ACCEPTABLE TO THE CITY OF MARYVILLE (COM).

SANITARY SEWER SPECIAL NOTES:

SEWERS IN FILL - SEWER LINES LAID IN FILL SHALL BE:

- C900
- INSTALLED ON PIERS THIS REQUIREMENT MAY BE WAIVED IN WHOLE OR IN PART BY WSD IF SUFFICIENT COMPACTION HAS BEEN ACHIEVED IN THE FILL (95% AASHTO T-99 MINIMUM).

MANHOLE DEPTHS - SHALL BE THE CONTRACTORS RESPONSIBILITY TO BRING THE FINISH MANHOLE TOPS INTO CONFORMANCE WITH THE FINISH GRADE AND/OR GROUND SURFACE.

MANHOLE INVERTS - WHEN THE DEFLECTION ANGLE IN THE INVERT OF A MANHOLE EXCEEDS 90° THE CITY OF MARYVILLE (COM) REQUIRES THAT:

- THE INLET INVERT BE AT LEAST 2 INCHES HIGHER THAN THE OUTLET INVERT.
- THE CHANNEL FROM THE INLET TO THE OUTLET SHALL BE FORMED SO NO NO FLOW ENTERS THE MAIN FLOW STREAM COUNTER TO THE MAIN DIRECTION OF THE FLOW.

DEEP SEWER LINES - WHERE THE EXISTING COVER IS MORE THAN 16 FEET OVER THE PROPOSED SEWER LINE, THE GROUND MUST BE GRADED TO LESS THAN 16 FEET OF COVER OVER THE PROPOSED SEWER LINE PRIOR TO SEWER CONSTRUCTION OR THE SEWER LINE MUST BE CONSTRUCTED OF C900. IN ALL CASES WHERE THE FINAL COVER OVER THE SEWER LINE IS GREATER THAN 16 FEET, THE SEWER LINE SHALL BE CONSTRUCTED OF C900.

SHALLOW SEWER LINES - WHERE THE EXISTING COVER DEPTH IS LESS THAN 2 1/2 FEET IN OPEN AREAS OR 4 FEET IN ROADWAYS, THE UTILITY LINE SHALL BE C900. WHERE REQUIRED BY THE CITY OF MARYVILLE (COM) CONCRETE ENCASEMENTS SHALL BE USED. IF FILL IS USED TO MEET MINIMUM COVER REQUIREMENTS, THE FILL MUST BE IN PLACE PRIOR TO UTILITY LINE INSTALLATION.

VACUUM TESTING - ALL MANHOLES WILL BE VACUUM TESTED AS PER THE CITY OF MARYVILLE (COM) AS PER THE CITY OF MARYVILLE AND STATE OF TENNESSEE REQUIREMENTS PRIOR TO ACCEPTANCE.

TRENCH DAMS - TRENCH DAMS SHALL BE INSTALLED IN THE BEDDING AND BACKFILL AT ALL JUNCTIONS OF FILL AND NATIVE SOIL, AND UPSTREAM OF EACH MANHOLE TO LIMIT THE FRENCH DRAIN EFFECT OF THE GRAVEL BEDDING. THE MAXIMUM SPACING BETWEEN TRENCH DAMS SHALL BE 500 FEET. TRENCH DAMS SHALL CONSIST OF 4,000 PSI CONCRETE AND BACKFILL AT LEAST THREE FEET THICK TO THE TOP OF THE TRENCH AND CUT INTO THE WALLS OF THE TRENCH TWO FEET.

TEES AND LATERALS - ALL TEES AND LATERALS CONNECTED TO C900 SEWER MAINS AND ALL LATERALS CONNECTED TO MANHOLES, 16 FEET OR MORE IN DEPTH, SHALL BE C900.

MANHOLE COUPLINGS - ALL MANHOLE COUPLINGS (BOOTS) SHALL BE "STEEL BAND FERROCO BOOTS" WHENEVER THE SLOPE OF THE LINE ENTERING OR EXISTING THE MANHOLE IS 10% OR GREATER.

TRENCH BOTTOM CONDITIONS - TRENCH BOTTOM MAY BE REQUIRED TO BE UNDERCUT TO A FIRM BASE AND BACK FILLED WITH STONE TO PREVENT SETTLING IN AREAS OF UNSATISFACTORY MATERIAL. SUCH A DETERMINATION WILL BE MADE BY THE CITY OF MARYVILLE (COM) AT THE TIME OF CONSTRUCTION.

SPECIFICATIONS:

- LOAD RATING: HEAVY DUTY
- MATERIAL SPECIFICATION: ASTM-A48 CLASS 30
- TOTAL WEIGHT OF FRAMES & COVERS: STANDARD: 375 LBS. (MIN.) WATERTIGHT: 485 LBS. (MIN.)
- COVER FACE SHALL BE EMBOSSED WITH THE SEAL OF THE CITY OF MARYVILLE AS SHOWN.
- MANHOLE FRAME & COVER VENDOR DWGS. SHALL BE SUBMITTED TO THE MARYVILLE WATER & SEWER (WSD) DEPARTMENT AND APPROVED BY WSD PERSONNEL PRIOR TO ACCEPTANCE OF MANHOLE FRAMES & COVER.
- NO VARIATIONS OF MANHOLE FRAME & COVER DIMS. OR SPECS. SHALL BE ACCEPTED EXCEPT WHERE NOTED ON THIS DWG.

ADDITIONAL NOTES:

- ALL MH PARTS TO MEET C.O.M. STANDARDS
- PERFORATED COVER MAY BE USED IN LIEU OF VENTS WITH C.O.M. APPROVAL.
- CONTRACTOR TO VERIFY ADEQUATE SIZE OF MANHOLE FOR VALVE USED.
- VERIFY PROPOSED TOP ACCESS MATERIALS AND OPENING SIZE WITH WATER & SEWER DEPT. (WSD) PRIOR TO ORDERING MATERIALS. OPENING MUST MEET WSD REQUIREMENTS FOR ACCESS WHICH MAY VARY WITH SIZE OF AIR RELEASE VALVE, TRAFFIC CONDITIONS, DEPTH OF LINE, AND OTHER ON SITE CONDITIONS.
- GENERALLY A STD. FRAME AND GRATE, OR BILCO TYPE HATCH WITH A 24"x24" OR LARGER OPENING WILL BE REQUIRED. VERIFY TYPE OF ACCESS, OPENING SIZE, AND MATERIAL WITH WSD PRIOR TO ORDERING THE PRECAST FLAT TOP. UNAPPROVED ACCESS MAY BE REJECTED BY THE CITY OF MARYVILLE.

WATER & SEWER DEPARTMENT
CITY OF MARYVILLE
MARYVILLE, TENNESSEE



DRAWN BY: GEF
APP'D BY: JG
DATE: _____
LAST REV DATE: 10/28/25
DESCRIPTION: _____

TITLE: STANDARD DETAIL DWGS. SEWER
SCALE: NONE
SHEET 1 of 2

W.O.

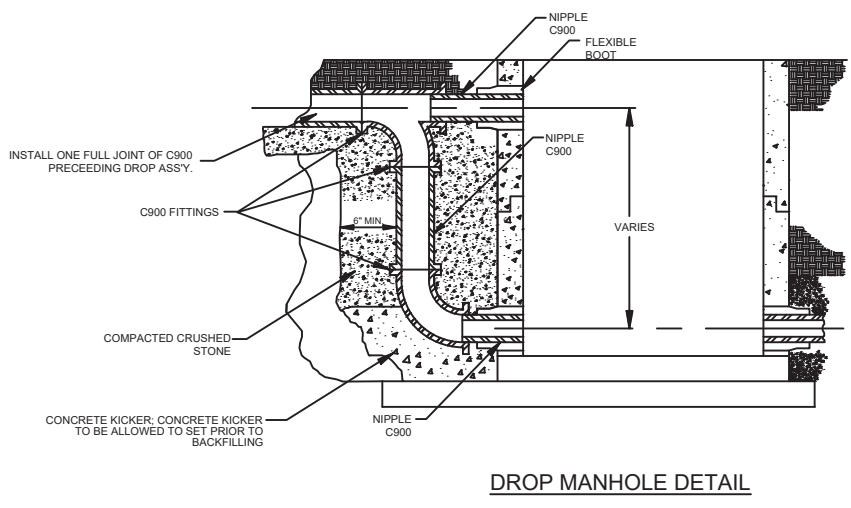

DROP MANHOLE DETAIL

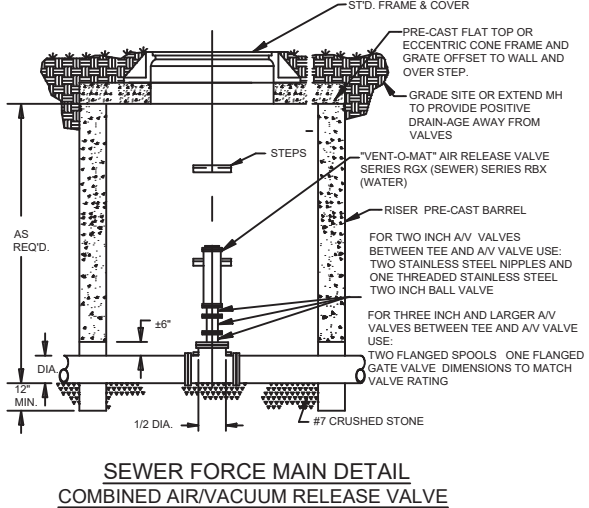

SEWER FORCE MAIN DETAIL COMBINED AIR/VACUUM RELEASE VALVE

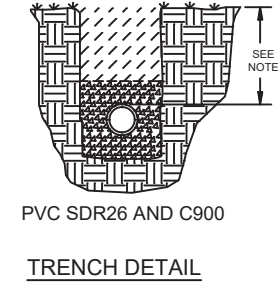

TRENCH DETAIL

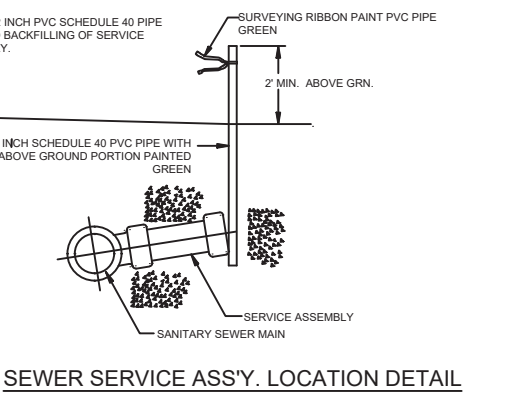

SEWER SERVICE ASS'Y. LOCATION DETAIL

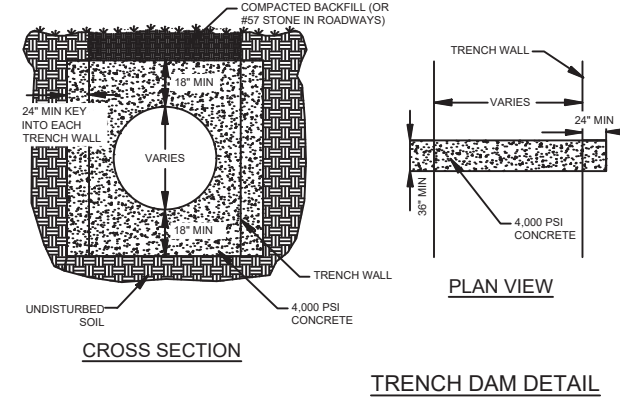

CROSS SECTION

PLAN VIEW

- NOTES:
- THE KEY SHALL EXTEND INTO UNDISTURBED MATERIAL; EXTENDING THE TRENCH LATERALLY TO THE TRENCH EDGES IS OPTIONAL.
 - FOR TRENCH DAMS USED FOR SEWER PIPING, FREQUENCY OF PLACEMENT SHALL BE AS SPECIFIED BY THE ENGINEER ON THE CONSTRUCTION DRAWINGS WITH:
- SANITARY SEWERS SHALL HAVE A MINIMUM OF ONE TRENCH DAM ON EACH PIPE RUN BETWEEN MANHOLES OR STRUCTURES.
- TRENCH DAMS SHALL BE LOCATED APPROXIMATELY 14 FEET UPSTREAM OF MANHOLES, LIFT STATIONS, OR OTHER STRUCTURES.
- PIPES INSTALLED THROUGH EMBANKMENTS AND CREEK CROSSINGS SHALL REQUIRE TRENCH DAMS AT SPECIFIC INTERVALS AS DIRECTED BY THE ENGINEER.
- CERTAIN CONDITIONS MAY REQUIRE MORE FREQUENT PLACEMENT OF TRENCH DAMS, AS SPECIFIED BY THE ENGINEER.
- SOIL COVER ABOVE TRENCH DAMS SHALL EXTEND TO FINISH GRADE, EXCEPT IN ROADWAY AREAS, WHERE CLEAN #57 STONE SHALL BE USED TO FINISH GRADE.

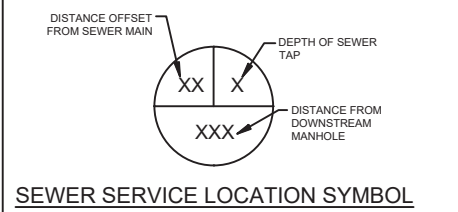

SEWER SERVICE LOCATION SYMBOL

SPECIFICATIONS:

- STRUCTURAL DESIGN: THE PRE-CAST GREASE TRAP SHALL BE DESIGNED TO REMAIN WATERTIGHT AND STRUCTURALLY SOUND WITHOUT CRACKING UNDER THE MAXIMUM COVER HEIGHT EIGHT (8) FEET OF COVER ON A TRAFFIC RATED TRAP. ALSO THE TRAPS BAFFLE SHALL BE POURED MONOLITHICALLY WITH THE BOTTOM OF THE TRAP. GREASE TRAPS SHALL BE TOP SEAMED UNLESS OTHERWISE APPROVED BY THE CONTROL AUTHORITY. THE DESIGN MUST SHOW THAT WATERTIGHT INTEGRITY IS ACHIEVED THROUGH THE USE OF QUALITY CONCRETE RATHER THAN THROUGH AN IMPERVIOUS BARRIER. USE OF INTERIOR OR EXTERIOR COATINGS IS NOT ACCEPTABLE AS A PRIMARY WATER TIGHTNESS SYSTEM.
- INTERNAL PLUMBING: NEOPRENE BOOTS WITH STAINLESS STEEL LOCKING BANDS SHALL BE USED ON ALL INLET AND OUTLET PIPES TO ENSURE A WATERTIGHT SEAL BETWEEN THE TANK WALL AND THE INLET AND OUTLET PIPES. MINIMUM PIPE SIZE AND TEES SHALL BE FOUR (4) INCH SCHEDULE 40 (ASTM D-2865).
- GRADE RINGS, MANHOLE FRAME, AND LIDS: WHEN THE ELEVATION OF THE TOP OF THE GREASE TRAP MANHOLE FRAMES AND LIDS NEEDS TO BE RAISED, CONCRETE GRADE RINGS SHALL BE USED AND SEALED WITH BITUMASTIC SEALER BETWEEN THEM. ALSO ALL GRADE RINGS SHALL BE COATED WITH BITUMINOUS ROOFING MATERIAL. ALL LIDS SHALL BE NON VENTED AND BE LABELED GREASE.
- MINIMUM REQUIREMENTS: PRE-CAST GREASE TRAPS SHALL HAVE A MINIMUM WALL THICKNESS OF SEVEN (7) INCHES AT THE TOP AND SEVEN (7) INCHES AT THE BOTTOM AND MINIMUM THICKNESS OF SEVEN AND HALF (7 1/2) INCHES FOR THE WALL THICKNESS. THE CEMENT SHALL BE PORTLAND CEMENT CONFORMING TO THE CURRENT ASTM SPECIFICATION C-150, TYPE I PORTLAND, NORMAL, GREY COLOR. TYPE III PORTLAND, GREY COLOR SHALL BE USED WHERE HIGH EARLY STRENGTH CONCRETE IS SPECIFIED. PRE-CAST GREASE TRAPS SHALL BE CURED FOR A MINIMUM OF 24 HOURS. THE MAXIMUM WATER-TO-CEMENT RATIO SHALL BE 0.45. MINIMUM PRE-CAST GREASE TRAP SIZE SHALL BE 1000 GALLONS.
- TEST FOR WATERTIGHT INTEGRITY: THE CONTROL AUTHORITY SHALL VACUUM TEST THE GREASE TRAP FOR WATER-TIGHTNESS, AT THE CONTRACTOR'S EXPENSE. TESTS SHALL BE PERFORMED UPON INSTALLATION PRIOR TO FINAL BACKFILLING. THE INTENT OF THE TEST IS TO ENSURE A WATERTIGHT GREASE TRAP UNDER GROUNDWATER CONDITIONS. THE VACUUM TEST WILL CONSIST OF TESTING TRAP, AND GRADE RINGS IF ATTACHED, TO THE TOP OF THE MANHOLE RING AND LID AT THE TIME OF TESTING. TESTING PRESSURE WILL BE 4 PSI FOR 5 MINUTES.
- INSTALLATION REQUIREMENTS: GREASE TRAPS SHALL BE BURIED NO MORE THAN EIGHT (8) FEET DEEP UNLESS PRIOR APPROVAL IS GIVEN BY THE CONTROL AUTHORITY. THE CONTROL AUTHORITY SHALL INSPECT THE TRAP TO INSURE THAT TRAP IS LEVEL BEFORE IT IS BACKFILLED. THE GREASE TRAP SHALL HAVE A MINIMUM FALL OF THREE (3) INCHES AND MAXIMUM FALL OF FIVE (5) INCHES THROUGH THE TRAP. BITUMASTIC SEALER SHALL BE USED TO SEAL ALL TANK JOINTS. THE TRAP SHALL BE BEDDED WITH A MINIMUM OF 6-INCHES OF NO. 57 CRUSHED STONE. TRAPS LOCATED IN TRAFFIC AREAS SHALL BE COMPLETELY BACKFILLED WITH NO. 57 CRUSHED STONE.

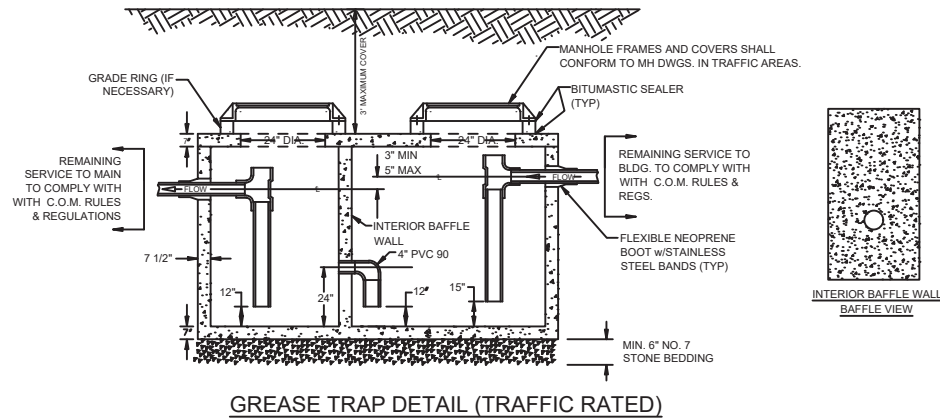

SPECIFICATIONS:

- STRUCTURAL DESIGN: THE PRE-CAST GREASE TRAP SHALL BE DESIGNED TO REMAIN WATERTIGHT AND STRUCTURALLY SOUND WITHOUT CRACKING UNDER THE MAXIMUM COVER HEIGHT OF THREE (3) FEET OF COVER ON A NON TRAFFIC RATED TRAP, OR EIGHT (8) FEET OF COVER ON A TRAFFIC RATED TRAP. ALSO THE TRAPS BAFFLE SHALL BE POURED MONOLITHICALLY WITH THE BOTTOM OF THE TRAP. GREASE TRAPS SHALL BE TOP SEAMED UNLESS OTHERWISE APPROVED BY THE CONTROL AUTHORITY. THE DESIGN MUST SHOW THAT WATERTIGHT INTEGRITY IS ACHIEVED THROUGH THE USE OF QUALITY CONCRETE RATHER THAN THROUGH AN IMPERVIOUS BARRIER. USE OF INTERIOR OR EXTERIOR COATINGS IS NOT ACCEPTABLE AS A PRIMARY WATER TIGHTNESS SYSTEM.
- INTERNAL PLUMBING: NEOPRENE BOOTS WITH STAINLESS STEEL LOCKING BANDS SHALL BE USED ON ALL INLET AND OUTLET PIPES TO ENSURE A WATERTIGHT SEAL BETWEEN THE TANK WALL AND THE INLET AND OUTLET PIPES. MINIMUM PIPE SIZE AND TEES SHALL BE FOUR (4) INCH SCHEDULE 40 (ASTM D-2865).
- GRADE RINGS, MANHOLE FRAME, AND LIDS: WHEN THE ELEVATION OF THE TOP OF THE GREASE TRAP MANHOLE FRAMES AND LIDS NEEDS TO BE RAISED, CONCRETE GRADE RINGS SHALL BE USED AND SEALED WITH BITUMASTIC SEALER BETWEEN THEM. ALSO ALL GRADE RINGS SHALL BE COATED WITH BITUMINOUS ROOFING MATERIAL. ALL LIDS SHALL BE NON VENTED AND BE LABELED GREASE.
- MINIMUM REQUIREMENTS: PRE-CAST GREASE TRAPS SHALL HAVE A MINIMUM WALL THICKNESS OF FIVE (5) INCHES AND MINIMUM THICKNESS OF SIX (6) INCHES FOR THE TOP AND FOUR (4) INCHES FOR THE BOTTOM. THE CEMENT SHALL BE PORTLAND CEMENT CONFORMING TO THE CURRENT ASTM SPECIFICATION C-150, TYPE I PORTLAND, NORMAL, GREY COLOR. TYPE III PORTLAND, GREY COLOR SHALL BE USED WHERE HIGH EARLY STRENGTH CONCRETE IS SPECIFIED. PRE-CAST GREASE TRAPS SHALL BE CURED FOR A MINIMUM OF 24 HOURS. THE MAXIMUM WATER-TO-CEMENT RATIO SHALL BE 0.45. MINIMUM PRE-CAST GREASE TRAP SIZE SHALL BE 1000 GALLONS.
- TEST FOR WATERTIGHT INTEGRITY: THE CONTROL AUTHORITY SHALL VACUUM TEST THE GREASE TRAP FOR WATER-TIGHTNESS, AT THE CONTRACTOR'S EXPENSE. TESTS SHALL BE PERFORMED UPON INSTALLATION PRIOR TO FINAL BACKFILLING. THE INTENT OF THE TEST IS TO ENSURE A WATERTIGHT GREASE TRAP UNDER GROUNDWATER CONDITIONS. THE VACUUM TEST WILL CONSIST OF TESTING TRAP, AND GRADE RINGS IF ATTACHED, TO THE TOP OF THE MANHOLE RING AND LID AT THE TIME OF TESTING. TESTING PRESSURE WILL BE 4 PSI FOR 5 MINUTES.
- INSTALLATION REQUIREMENTS: GREASE TRAPS SHALL BE BURIED NO MORE THAN THREE (3) FEET DEEP UNLESS PRIOR APPROVAL IS GIVEN BY THE CONTROL AUTHORITY. THE CONTROL AUTHORITY SHALL INSPECT THE TRAP TO INSURE THAT TRAP IS LEVEL BEFORE IT IS BACKFILLED. THE GREASE TRAP SHALL HAVE A MINIMUM FALL OF THREE (3) INCHES AND MAXIMUM FALL OF FIVE (5) INCHES THROUGH THE TRAP. BITUMASTIC SEALER SHALL BE USED TO SEAL ALL TANK JOINTS. THE TRAP SHALL BE BEDDED WITH A MINIMUM OF 6-INCHES OF NO. 7 CRUSHED STONE. TRAPS LOCATED IN TRAFFIC AREAS SHALL BE COMPLETELY BACKFILLED WITH CLEAN CRUSHED STONE.

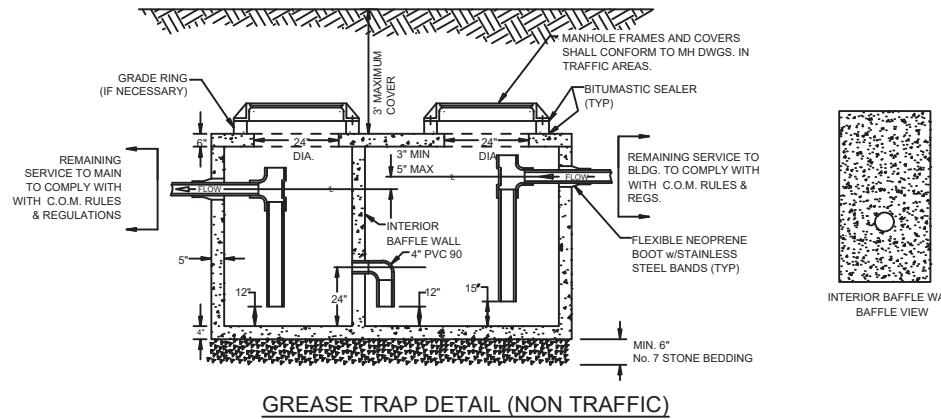

SPECIFICATIONS:

- STRUCTURAL DESIGN: THE PRE-CAST OIL/GRIT SEPARATOR SHALL BE DESIGNED TO REMAIN WATERTIGHT AND STRUCTURALLY SOUND WITHOUT CRACKING UNDER THE MAXIMUM COVER HEIGHT OF EIGHT (8) FEET OF COVER ON A TRAFFIC RATED TRAP. ALSO THE TRAPS BAFFLE SHALL BE POURED MONOLITHICALLY WITH THE BOTTOM OF THE TRAP. OIL/GRIT SEPARATORS SHALL BE TOP SEAMED UNLESS OTHERWISE APPROVED BY CONTROL AUTHORITY. THE DESIGN MUST SHOW THAT WATERTIGHT INTEGRITY IS ACHIEVED THROUGH THE USE OF QUALITY CONCRETE RATHER THAN THROUGH AN IMPERVIOUS BARRIER. USE OF INTERIOR OR EXTERIOR COATINGS IS NOT ACCEPTABLE AS A PRIMARY WATER TIGHTNESS SYSTEM.
- INTERNAL PLUMBING: NEOPRENE BOOTS WITH STAINLESS STEEL LOCKING BANDS SHALL BE USED ON ALL INLET AND OUTLET PIPES TO ENSURE A WATERTIGHT SEAL BETWEEN THE TANK WALL AND THE INLET AND OUTLET PIPES. MINIMUM PIPE SIZE AND TEES SHALL BE FOUR (4) INCH SCHEDULE 40 (ASTM D-2865).
- GRADE RINGS, MANHOLE FRAME, AND LIDS: WHEN THE ELEVATION OF THE TOP OF THE OIL/GRIT SEPARATOR MANHOLE FRAMES AND LIDS NEEDS TO BE RAISED, CONCRETE GRADE RINGS SHALL BE USED AND SEALED WITH BITUMASTIC SEALER BETWEEN THEM. ALSO ALL GRADE RINGS SHALL BE COATED WITH BITUMINOUS ROOFING MATERIAL. ALL LIDS SHALL BE NON VENTED AND BE LABELED GRIT.
- MINIMUM REQUIREMENTS: PRE-CAST OIL/GRIT SEPARATORS SHALL HAVE A MINIMUM WALL THICKNESS SEVEN AND A HALF (7.5) INCHES AND A MINIMUM THICKNESS OF SEVEN (7) INCHES FOR THE BOTTOM AND SEVEN (7) INCHES FOR THE TOP. THE CEMENT SHALL BE PORTLAND CEMENT CONFORMING TO THE CURRENT ASTM SPECIFICATION C-150, TYPE I PORTLAND, NORMAL, GREY COLOR. TYPE III PORTLAND, GREY COLOR SHALL BE USED WHERE HIGH EARLY STRENGTH CONCRETE IS SPECIFIED. PRE-CAST OIL/GRIT SEPARATOR SHALL BE CURED FOR A MINIMUM OF 24 HRS. THE MAXIMUM WATER-TO-CEMENT RATIO SHALL BE 0.45. MINIMUM PRE-CAST OIL/GRIT SEPARATOR SIZE SHALL BE 1000 GALLONS.
- TEST FOR WATERTIGHT INTEGRITY: THE CONTROL AUTHORITY SHALL VACUUM TEST THE OIL/GRIT SEPARATOR FOR WATER-TIGHTNESS AT THE CONTRACTOR'S EXPENSE. TESTS SHALL BE PERFORMED UPON INSTALLATION PRIOR TO FINAL BACKFILLING. THE INTENT OF THE TEST IS TO ENSURE A WATERTIGHT OIL/GRIT SEPARATOR UNDER GROUNDWATER CONDITIONS. THE VACUUM TEST WILL CONSIST OF TESTING THE SEPARATOR AND GRADE RINGS IF ATTACHED, TO THE TOP OF THE MANHOLE RING AND LID AT THE TIME OF TESTING. TESTING PRESSURE WILL BE 4 PSI FOR 5 MINUTES.
- INSTALLATION REQUIREMENTS: OIL/GRIT SEPARATORS SHALL BE BURIED NO MORE THAN EIGHT (8) FEET DEEP UNLESS PRIOR APPROVAL IS GIVEN BY THE CONTROL AUTHORITY. THE CONTROL AUTHORITY SHALL INSPECT THE SEPARATOR TO INSURE THAT SEPARATOR IS LEVEL BEFORE IT IS BACKFILLED. THE OIL/GRIT SEPARATOR SHALL HAVE A MINIMUM FALL OF THREE (3) INCHES AND MAXIMUM FALL OF FIVE (5) INCHES THROUGH THE SEPARATOR. BITUMASTIC SEALER SHALL BE USED TO SEAL ALL TANK JOINTS. THE SEPARATOR SHALL BE BEDDED WITH A MINIMUM OF 6-INCHES OF NO. 7 CRUSHED STONE. SEPARATOR LOCATED IN TRAFFIC AREAS SHALL BE COMPLETELY BACKFILLED WITH CLEAN CRUSHED STONE.

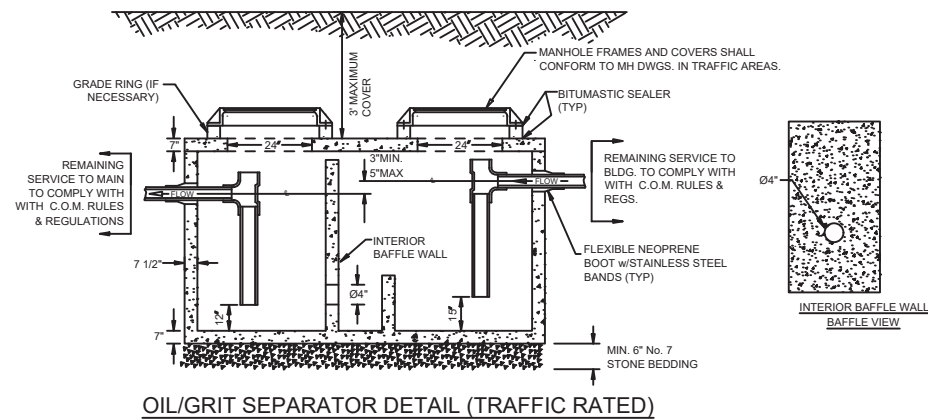

SPECIFICATIONS:

- STRUCTURAL DESIGN: THE PRE-CAST OIL/GRIT SEPARATOR SHALL BE DESIGNED TO REMAIN WATERTIGHT AND STRUCTURALLY SOUND WITHOUT CRACKING UNDER THE MAXIMUM COVER HEIGHT OF THREE (3) FEET OF COVER ON A NON TRAFFIC RATED TRAP, OR EIGHT (8) FEET OF COVER ON A TRAFFIC RATED TRAP. ALSO THE TRAPS BAFFLE SHALL BE POURED MONOLITHICALLY WITH THE BOTTOM OF THE TRAP. OIL/GRIT SEPARATORS SHALL BE TOP SEAMED UNLESS OTHERWISE APPROVED BY CONTROL AUTHORITY. THE DESIGN MUST SHOW THAT WATERTIGHT INTEGRITY IS ACHIEVED THROUGH THE USE OF QUALITY CONCRETE RATHER THAN THROUGH AN IMPERVIOUS BARRIER. USE OF INTERIOR OR EXTERIOR COATINGS IS NOT ACCEPTABLE AS A PRIMARY WATER TIGHTNESS SYSTEM.
- INTERNAL PLUMBING: NEOPRENE BOOTS WITH STAINLESS STEEL LOCKING BANDS SHALL BE USED ON ALL INLET AND OUTLET PIPES TO ENSURE A WATERTIGHT SEAL BETWEEN THE TANK WALL AND THE INLET AND OUTLET PIPES. MINIMUM PIPE SIZE AND TEES SHALL BE FOUR (4) INCH SCHEDULE 40 (ASTM D-2865).
- GRADE RINGS, MANHOLE FRAME, AND LIDS: WHEN THE ELEVATION OF THE TOP OF THE OIL/GRIT SEPARATOR MANHOLE FRAMES AND LIDS NEEDS TO BE RAISED, CONCRETE GRADE RINGS SHALL BE USED AND SEALED WITH BITUMASTIC SEALER BETWEEN THEM. ALSO ALL GRADE RINGS SHALL BE COATED WITH BITUMINOUS ROOFING MATERIAL. ALL LIDS SHALL BE NON VENTED AND BE LABELED GRIT.
- MINIMUM REQUIREMENTS: PRE-CAST OIL/GRIT SEPARATORS SHALL HAVE A MINIMUM WALL THICKNESS OF FIVE (5) INCHES AND A MINIMUM THICKNESS OF SIX (6) INCHES FOR THE TOP AND FOUR (4) INCHES FOR THE BOTTOM. THE CEMENT SHALL BE PORTLAND CEMENT CONFORMING TO THE CURRENT ASTM SPECIFICATION C-150, TYPE I PORTLAND, NORMAL, GREY COLOR. TYPE III PORTLAND, GREY COLOR SHALL BE USED WHERE HIGH EARLY STRENGTH CONCRETE IS SPECIFIED. PRE-CAST OIL/GRIT SEPARATOR SHALL BE CURED FOR A MINIMUM OF 24 HRS. THE MAXIMUM WATER-TO-CEMENT RATIO SHALL BE 0.45. MINIMUM PRE-CAST OIL/GRIT SEPARATOR SIZE SHALL BE 1000 GALLONS.
- TEST FOR WATERTIGHT INTEGRITY: THE CONTROL AUTHORITY SHALL VACUUM TEST THE OIL/GRIT SEPARATOR FOR WATER-TIGHTNESS, AT THE CONTRACTOR'S EXPENSE. TESTS SHALL BE PERFORMED UPON INSTALLATION PRIOR TO FINAL BACKFILLING. THE INTENT OF THE TEST IS TO ENSURE A WATERTIGHT OIL/GRIT SEPARATOR UNDER GROUNDWATER CONDITIONS. THE VACUUM TEST WILL CONSIST OF TESTING THE SEPARATOR, AND GRADE RINGS IF ATTACHED, TO THE TOP OF THE MANHOLE RING AND LID AT THE TIME OF TESTING. TESTING PRESSURE WILL BE 4 PSI FOR 5 MINUTES.
- INSTALLATION REQUIREMENTS: OIL/GRIT SEPARATORS SHALL BE BURIED NO MORE THAN THREE (3) FEET DEEP UNLESS PRIOR APPROVAL IS GIVEN BY THE CONTROL AUTHORITY. THE CONTROL AUTHORITY SHALL INSURE THAT SEPARATOR IS LEVEL BEFORE IT IS BACKFILLED. THE OIL/GRIT SEPARATOR SHALL HAVE A MINIMUM FALL OF THREE (3) INCHES AND MAXIMUM FALL OF FIVE (5) INCHES THROUGH THE SEPARATOR. BITUMASTIC SEALER SHALL BE USED TO SEAL ALL TANK JOINTS. THE SEPARATOR SHALL BE BEDDED WITH A MINIMUM OF 6-INCHES OF NO. 7 CRUSHED STONE. SEPARATOR LOCATED IN TRAFFIC AREAS SHALL BE COMPLETELY BACKFILLED WITH CLEAN CRUSHED STONE.

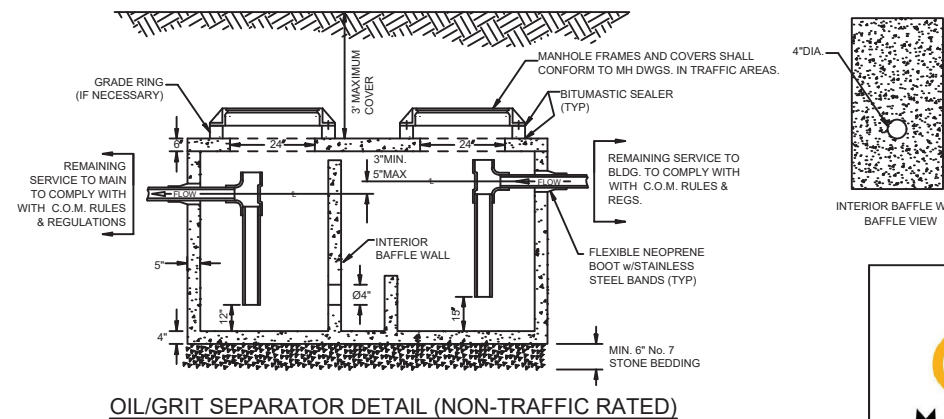

WATER & SEWER DEPARTMENT
CITY OF MARYVILLE
MARYVILLE, TENNESSEE

DRAWN BY: GEF	TITLE: STANDARD DETAIL DWGS. SEWER	SCALE: NONE
APP'D BY: JG		SHEET 2 of 2
DATE: 10/28/25		
DESCRIPTION:		W.O.

REVISION 3/10/99: AS AN ALTERNATE "SWIVEL" OR APPROVED EQUAL FITTING MAY BE USED PROVIDED THE INDICATED DIMENSIONS ARE MAINTAINED.

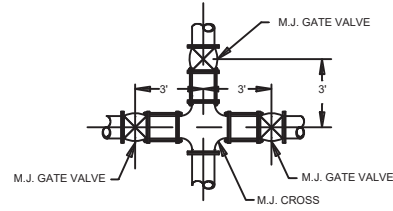

VALVE LOCATIONS @ CROSS

NOTE: IN LOCATIONS WHERE THE VALVE OR VALVE AND CAP ARE LIKELY TO BE DISTURBED OR ARE FOR A TEMPORARY "DEAD END" THE USE OF "ALL THREAD" AS SHOWN IN THE FIRE HYDRANT DETAIL WILL BE REQUIRED BY THE CITY OF MARYVILLE.

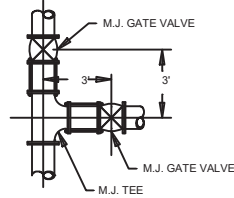

VALVE LOCATIONS @ TEE

- NOTES:
- PIPE BEDDING - A CONTINUOUS AND UNIFORM BEDDING SHALL BE PROVIDED IN THE TRENCH FOR ALL BURIED PIPE.
 - PIPE COVER - ALL DISTRIBUTOR MAINS SHALL BE PROVIDED WITH SUFFICIENT EARTH OR OTHER SUITABLE COVER TO PREVENT FREEZING AND PROVIDE PROTECTION TO THE PIPE. THE COVER SHALL NOT BE LESS THAN 36 INCHES FOR 6-INCH AND 8-INCH PIPE AND 42-INCHES FOR 10-INCH AND 12-INCH PIPE MEASURED ABOVE THE TOP OF THE PIPE. FOR 10-INCH AND 12-INCH PIPE MEASURED ABOVE THE TOP OF THE PIPE, REFERENCE THE MINIMUM DEPTH NOTES "WATER SYSTEM SPECIAL NOTES".

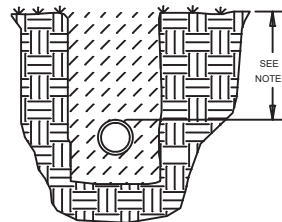

MLDI WATER LINE TRENCH DETAILS

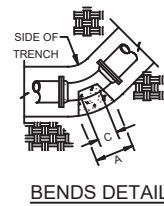

BENDS DETAIL

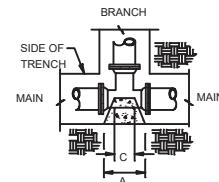

TEE DETAIL

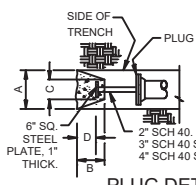

PLUG DETAIL

90 DEGREE BENDS

SIZE	2"	4"	6"	8"	10"	12"	18"
A	9"	18"	24"	32"	40"	46"	68"
B	9"	18"	24"	32"	40"	46"	68"
C	9"	9"	12"	12"	15"	16"	22"
D	8"	8"	12"	16"	20"	25"	24"

45 DEGREE BENDS

SIZE	2"	4"	6"	8"	10"	12"	18"
A	9"	13"	18"	24"	29"	34"	50"
B	9"	13"	18"	24"	29"	34"	50"
C	8"	8"	10"	12"	14"	16"	14"
D	6"	6"	9"	12"	15"	18"	18"

22 1/2 DEGREE BENDS

SIZE	2"	4"	6"	8"	10"	12"	18"
A	9"	9"	13"	18"	21"	24"	36"
B	9"	9"	13"	18"	21"	24"	36"
C	8"	8"	10"	12"	14"	16"	15"
D	4"	4"	6"	9"	11"	13"	16"

11 1/4 DEGREE BENDS

SIZE	2"	4"	6"	8"	10"	12"	18"
A	9"	9"	9"	12"	15"	18"	26"
B	9"	9"	9"	12"	15"	18"	26"
C	8"	8"	10"	12"	14"	16"	15"
D	4"	4"	5"	6"	8"	9"	16"

TEE

MAIN	2"-6"	8"-12"	8"-10"	12"	12"	12"	18"
BRANCH	2"-6"	2"-6"	8"-10"	2"-6"	8"-10"	12"	16"-18"
A	20"	20"	33"	20"	33"	39"	57"
B	20"	20"	33"	20"	33"	39"	57"
C	12"	12"	12"	12"	12"	12"	30"
D	13"	13"	21"	13"	21"	26"	24"

PLUG

SIZE	2"	4"	6"	8"	10"	12"	18"
A	12"	14"	20"	27"	33"	38"	56"
B	12"	14"	20"	27"	33"	38"	56"
C	12"	12"	12"	12"	12"	12"	30"
D	11"	11"	11"	15"	22"	32"	32"

- NOTES:
- THESE DIMENSIONS ARE MINIMUMS BASED ON 100 PSI WORKING LINE PRESSURES AND 2000 PSF SOIL BEARING CAPACITY. FOR OTHER WORKING PRESSURE AND/OR DIFFERENT SOIL BEARING CAPACITY THE DIMENSIONS SHALL BE RECALCULATED BY THE ENGINEER.
 - THRUST BLOCKS FOR PLUGS SHALL BE THE WIDER OF:
 - THE DIMENSION SHOWN ABOVE OR
 - THE WIDTH OF THE TRENCH PLUS 2 INCHES MEASURED AT THE SOIL BEARING SURFACE.
 - THE MINIMUM THRUST BLOCK DIMENSIONS IN CONTACT WITH THE BEARING SOIL SHALL BE 9 INCHES BY 9 INCHES.

THRUST BLOCK DETAILS

CITY OF MARYVILLE

GENERAL UTILITY NOTES:

ALL SEWER AND WATER EXTENSIONS SHALL BE BUILT IN ACCORDANCE WITH THE RULES, REGULATIONS, RATES, AND POLICIES OF THE CITY OF MARYVILLE, WATER & SEWER DEPARTMENT, MARYVILLE, TENNESSEE WHICH ARE AVAILABLE FROM THE CITY OF MARYVILLE (COM) AT WWW.MARYVILLEGOV.COM. IN CASES OF CONFLICT, THE CITY OF MARYVILLE (COM) REGULATIONS SHALL RULE. IT SHALL BE THE DEVELOPERS AND CONTRACTORS RESPONSIBILITY TO OBTAIN AND FOLLOW THE REGULATIONS OF THE CITY OF MARYVILLE (COM). EASEMENTS SHALL EXIST AS PER THE SUBDIVISION PLAT OR RECORDED EASEMENTS DOCUMENTS. IF THE NECESSARY EASEMENTS ARE NOT IN PLACE, THE DEVELOPER SHALL OBTAIN AND FURNISH THE CITY OF MARYVILLE (COM) WITH EASEMENTS FOR THE PORTIONS OR UTILITY LINES THAT CROSS PRIVATE PROPERTY. THE EASEMENT DOCUMENTS SHALL BE REVIEWED BY THE CITY OF MARYVILLE (COM) FOR ACCEPTABILITY PRIOR TO SIGNATURES. ALL EASEMENT DOCUMENTS SHALL BE RECORDED PRIOR TO CONSTRUCTION OF THE UTILITY LINES. ALL WATER AND SEWER LINES SHALL BE LAID IN UNDISTURBED NATIVE SOIL WHENEVER PRACTICAL. AT THE JUNCTION OF ALL UNDISTURBED SOIL AND FILL SECTIONS OF THE PIPE TRENCH, THE BACKFILL MATERIAL SHALL BE DIVIDED BY AN IMPERMEABLE SECTION OF FILL (E.G. COMPACTED CLAY) AROUND THE INSTALLED PIPE TO PREVENT PIPING OF WATER THROUGH THE PIPE BEDDING. UTILITIES CROSSING UNDER OTHER UTILITIES SHALL BE BACK FILLED WITH COMPACTED WITH NO. 7 STONE TO THE SPRING LINE OF THE UPPER UTILITY TO PREVENT SETTLING OF THE UTILITY. ANY UTILITY TRENCH LOCATED WITHIN A ROADWAY OR PAVED AREA, INCLUDING PRIVATE DRIVES AND PARKING LOTS, SHALL BE COMPLETELY BACKFILLED WITH COMPACTED STONE IN ACCORDANCE WITH CITY OF MARYVILLE REQUIREMENTS WATER AND SEWER SYSTEMS SHALL NOT BE GRANTED FINAL APPROVAL BY THE CITY OF MARYVILLE (COM) UNTIL "AS BUILT" DRAWINGS HAVE BEEN COMPLETED AND ARE ACCEPTABLE TO THE CITY OF MARYVILLE (COM).

WATER SYSTEM SPECIAL NOTES:

DEPTH - ALL WATER LINES SHALL BE INSTALLED A SUFFICIENT DEPTH TO PROVIDE FOR MINIMUM COVER OF NOT LESS THAN 36 INCHES FOR 6" AND 8" DIAMETER PIPES, 42 INCHES FOR 10", 12" AND 14" PIPE. COVER IS TO BE MEASURED FROM THE SUBGRADE ELEVATION AT THE CURB LINE OF THE ROAD ADJACENT TO THE PIPE LINE OR THE EXISTING GROUND AT THE TIME OF CONSTRUCTION OR THE FINISH GRADE DIRECTLY OVER THE PIPE, WHICHEVER IS LOWER. NO PIPE IS TO BE LAID SO THAT A DRIVEWAY WILL CREATE A SITUATION THAT WILL VIOLATE THE MINIMUM COVER REQUIREMENTS.

MATERIALS - ALL MATERIALS USED IN THE PROJECT SHALL BE ACCEPTABLE TO THE COM, WATER & SEWER DEPARTMENT. ALL WATER LINES GREATER THAN 2 INCHES IN DIAMETER SHALL BE CLASS 51 CEMENT MORTAR LINED DUCTILE IRON.

PRESSURE AND FLOW CONTROL - PRESSURE AND FLOW REDUCING VALVES SHALL BE INSTALLED IN EACH HOUSE OR AT EACH CONNECTION TO A STRUCTURE TO MAINTAIN DOMESTIC PRESSURE AT OR BELOW 80 PSI UNLESS THE PIPE SYSTEM HAS BEEN SPECIFICALLY DESIGNED TO HANDLE PRESSURES IN EXCESS OF 80 PSI AND PERMISSION IS OBTAINED FROM THE COM, WATER & SEWER DEPARTMENT.

- NOTES:
- WHERE A TWO INCH WATER METER IS TO BE INSTALLED, USE:
 - THE APPROPRIATE SIZED TEE.
 - THE SIX INCH GATE VALVES MAY BE ELIMINATED AND THE TAPPED END CAP (PLUG) PLACED DIRECTLY ON THE TEE.
 - A TWELVE INCH BRASS NIPPLE - THE NIPPLE SHALL BE INSTALLED LEVEL.
 - A TWO INCH WHEEL VALVE.
 - THE TWO INCH VALVE SHALL BE INSTALLED IN EITHER A VALVE BOX OR METER BOX.

THE CITY OF MARYVILLE WILL PROVIDE THE TWELVE INCH BRASS NIPPLE AND THE TWO INCH WHEEL VALVE.

2. ALL MECHANICAL JOINT FITTINGS SHALL INCLUDE COMPLETE BOLT AND GASKET ASSEMBLY PACKAGES.

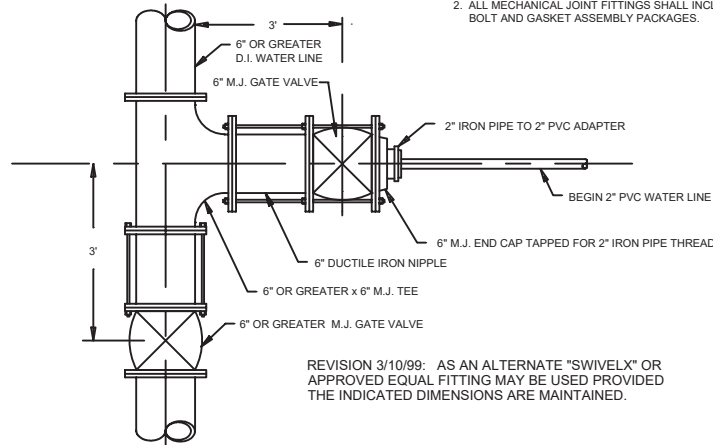

TIE-IN FOR 2" PVC WATER LINE TO 6" OR LARGER MAIN WATER LINE

REVISION 3/10/99: AS AN ALTERNATE "SWIVEL" OR APPROVED EQUAL FITTING MAY BE USED PROVIDED THE INDICATED DIMENSIONS ARE MAINTAINED.

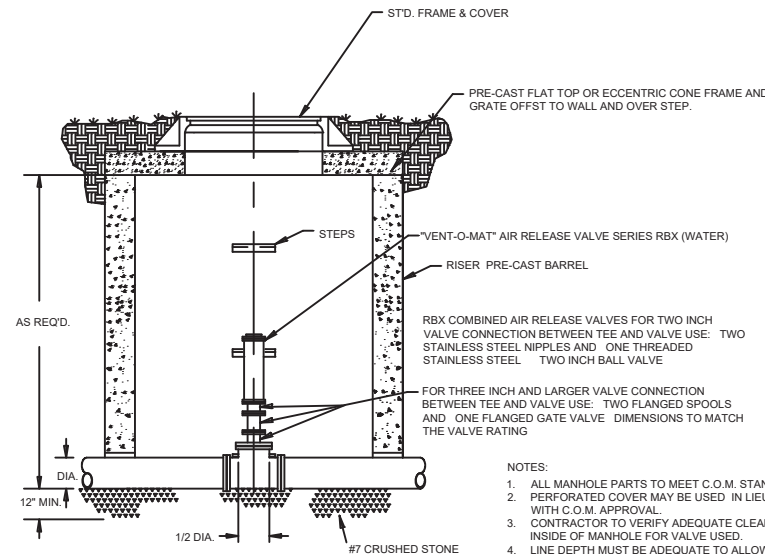

WATER LINE COMBINED AIR RELEASE VALVE

- NOTES:
- ALL MANHOLE PARTS TO MEET C.O.M. STANDARDS
 - PERFORATED COVER MAY BE USED IN LIEU OF VENTS WITH C.O.M. APPROVAL.
 - CONTRACTOR TO VERIFY ADEQUATE CLEARANCES INSIDE OF MANHOLE FOR VALVE USED.
 - LINE DEPTH MUST BE ADEQUATE TO ALLOW VALVE AND VALVE MANHOLE TO BE BELOW GROUND SURFACE.
 - VERIFY PROPOSED TOP ACCESS MATERIALS AND OPENING SIZE WITH CITY OF MARYVILLE WATER AND SEWER DEPARTMENT. (WSD) PRIOR TO ORDERING MATERIALS. OPENING MUST MEET WSD REQUIREMENTS FOR ACCESS WHICH MAY VARY WITH SIZE OF AIR RELEASE VALVE, TRAFFIC CONDITIONS, DEPTH OF LINE, AND OTHER ON SITE CONDITIONS.
 - GENERALLY A STD. FRAME AND GRATE, OR BILCO TYPE HATCH WITH A 24"x24" OR LARGER OPENING WILL BE REQUIRED. VERIFY TYPE OF ACCESS, OPENING SIZE, AND MATERIAL WITH WSD PRIOR TO ORDERING THE PRECAST FLAT TOP. UNAPPROVED ACCESS MAYBE REJECTED BY THE CITY OF MARYVILLE.

REVISION 3/10/99: AS AN ALTERNATE "SWIVEL" OR APPROVED EQUAL FITTING MAY BE USED PROVIDED THE INDICATED DIMENSIONS ARE MAINTAINED.

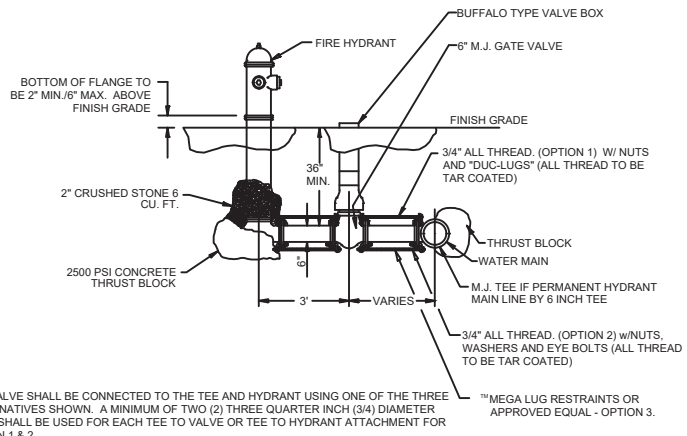

TYPICAL FIRE HYDRANT INSTALLATION

NOTE: THE VALVE SHALL BE CONNECTED TO THE TEE AND HYDRANT USING ONE OF THE THREE ALTERNATIVES SHOWN. A MINIMUM OF TWO (2) THREE QUARTER INCH (3/4) DIAMETER RODS SHALL BE USED FOR EACH TEE TO VALVE OR TEE TO HYDRANT ATTACHMENT FOR OPTION 1 & 2.



**WATER & SEWER DEPARTMENT
CITY OF MARYVILLE
MARYVILLE, TENNESSEE**

DRAWN BY: GEF	TITLE: STANDARD DETAIL DWGS. WATER	SCALE: NONE
APP'D BY: JG		SHEET 1 of 1
DATE:		
LAST REV DATE: 10/28/25		
DESCRIPTION:		W.O.

APPROVED ALTERNATIVES SHALL INCLUDE:
 1. CARSON - BROOKS PLASTIC, INC. WITH 1 1/2 INCH BY 10 INCH LID

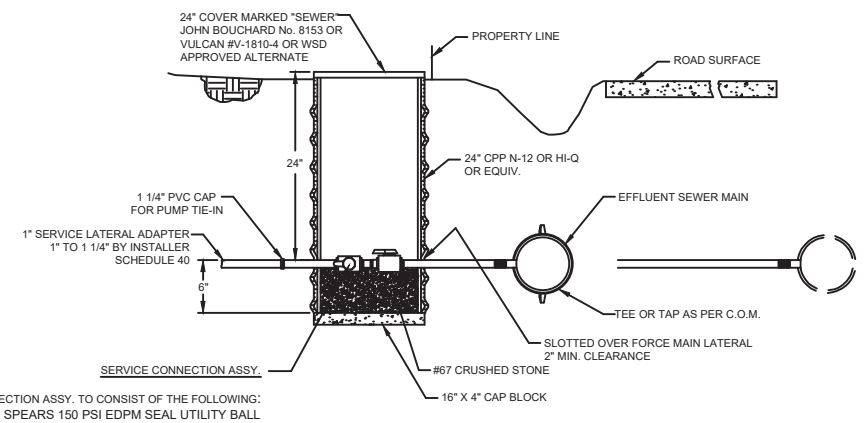

CONNECTION ASSY. TO CONSIST OF THE FOLLOWING:
 1 1/4" SPEARS 150 PSI EDPM SEAL UTILITY BALL VALVE SCH. 40 SPEARS #2622-012 (2) 1 1/4" TO 1 1/4" UNIONS - SLIP FITTING SCH. 40 SPEARS #457-012 FLOW CONTROL 1 1/4" SWING CHECK VALVE SCH. 40 FLOW CONTROL #1520-12 1 1/4" SCH. 40 PVC NIPPLES AS NEEDED TO MEET REQUIRED DIMENSIONS

S.T.E.P. SEWER SERVICE CONNECTION

ALL SERVICE LINE CONNECTIONS SHALL BE SOLVENT WELDED. THE ONLY ACCEPTABLE SOLVENTS AND CEMENTS ARE THOSE THAT ARE RECOMMENDED BY THE PIPE MANUFACTURER. ALL SERVICE LATERALS FROM THE EFFLUENT SEWER MAIN TO THE PROPERTY LINE SHALL BE PRESSURE TESTED PRIOR TO ANY BACKFILLING.

NOTE: WHEN THE TERMINAL FLUSHING CONNECTION IS OUTSIDE THE ROADWAY PAVEMENT THE USE OF A BOX SIMILAR IN CONSTRUCTION TO THE SEWER SERVICE CONNECTION MAY BE SUBSTITUTED WITH THE WATER & SEWER DEPARTMENT APPROVAL.

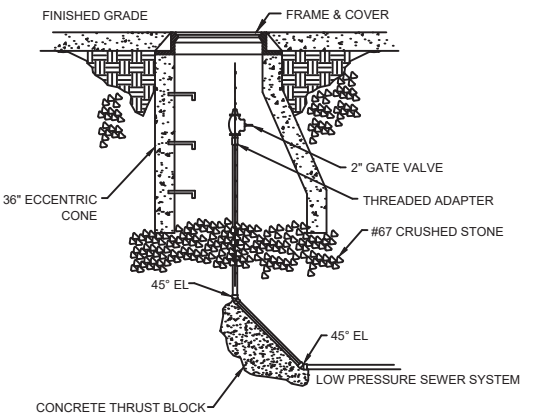

2" TERMINAL FLUSHING CONNECTION IN ROAD PAVEMENT

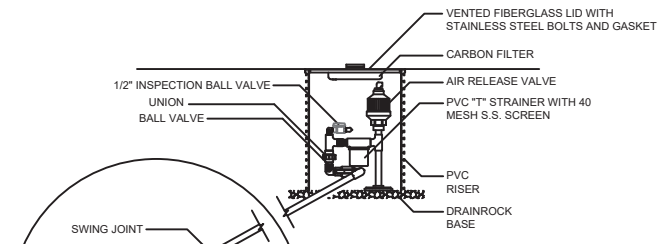

OSI'S AIR RELEASE ASSEMBLY IS SUPPLIED AS A COMPLETE PRE-ASSEMBLED UNIT WHICH CAN BE INSTALLED ABOVE OR BELOW GROUND. OSI'S AIR RELEASE ASSEMBLY CAN BE EASILY MODIFIED OR CUSTOM BUILT.

THIS UNIT'S LOW PROFILE IS A REAL ADVANTAGE WHEN USED WITH SHALLOWLY BURIED COLLECTION LINES COMMON TO PRESSURE SEWER AND WATER DISTRIBUTION SYSTEMS

THE 1/2 INCH BALL VALVE IS USED TO VERIFY THAT THE AUTOMATIC AIR-RELEASE VALVE IS OPERATIONAL. THE RELEASE OF A LARGE VOLUME OF AIR THROUGH THE 1/2 INCH BALL VALVE DURING OPERATION INDICATES THAT THE VALVE AND STRAINER SHOULD BE REMOVED AND CLEANED. THE FREQUENCY OF INSPECTION REQUIRED MAY VARY FROM ONE TO TWELVE MONTHS DEPENDING ON THE SYSTEM.

A PRESSURE GAUGE CAN BE THREADED INTO THE OUTLET END OF THE 1/2 INCH BALL VALVE TO OBSERVE SYSTEM LINE PRESSURE. ALL COMPONENTS ARE RATED FOR A 150 PSI WORKING PRESSURE.

© 1997, ORENCO SYSTEMS, INC. NOT SUPPLIED

1997, ORENCO SYSTEMS, INC.

TEST FOR WATERTIGHT INTEGRITY: THE CONTROL AUTHORITY SHALL VACUUM TEST THE PUMP TANK FOR WATER-TIGHTNESS, AT THE CONTRACTOR'S EXPENSE. TESTS SHALL BE PERFORMED UPON INSTALLATION PRIOR TO FINAL BACKFILLING. THE INTENT OF THE TEST IS TO ENSURE A WATERTIGHT PUMP TANK UNDER GROUNDWATER CONDITIONS. THE VACUUM TEST WILL CONSIST OF A TEST PRESSURE OF 4 PSI FOR 5 MINUTES.

SEPTIC TANK SIZING SHALL BE BASED ON THE FOLLOWING REQUIREMENTS:

NUMBER OF BEDROOMS	MINIMUM SIZE TANK
4 OR LESS	1500 GALLON TWO COMPARTMENT
5 OR GREATER	2000 GALLON TWO COMPARTMENT

OTHER BEDROOM CONFIGURATIONS OR INDUSTRIAL USES WILL BE BASED ON A TANK PUMPING FREQUENCY OF 10 YEARS AS DETERMINE IN THE SUGGESTED SPECIFICATIONS AS FURNISHED BY ORENCO SYSTEMS, INC. COMMERCIAL INSTALLATIONS ARE STRONGLY URGED TO CONSIDER MULTIPLE TANKS IN LIEU OF MULTIPLE COMPARTMENTS.

EDW-TD-20 Rev. 1.0 (2/98)

AIR RELEASE ASSEMBLY

ORENCO SYSTEMS INCORPORATED
 814 AIRWAY AVENUE
 SUTHERLIN, OREGON
 97479-9012

NOTE: ALTERNATE INSPECTION PORT AS PER THE 1000 GAL. TANK

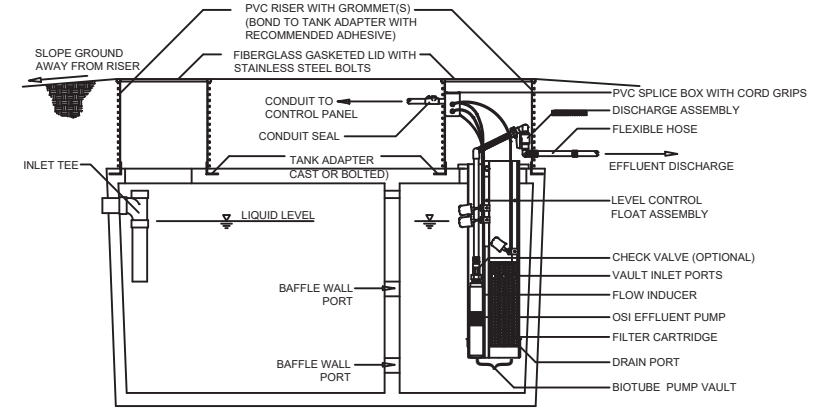

EDW-TD-4 Rev. 1.0 (2/98)

2 FLOAT

PATENTS # 4,439,323 & 5,492,635 FOREIGN PATENTS PENDING © 1997, ORENCO SYSTEMS, INC.

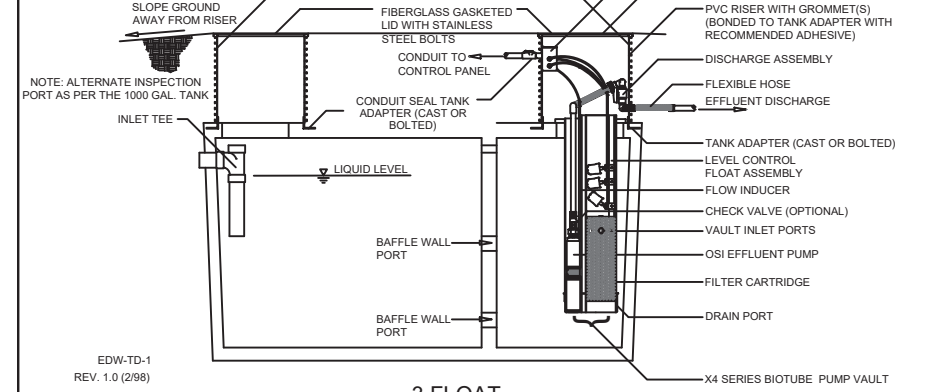

EDW-TD-1 Rev. 1.0 (2/98)

3 FLOAT

NOTE: OSI EFFLUENT PUMP 1/2 HP WILL HAVE (2) TWO FLOATS AND 1 HP WILL HAVE (3) THREE FLOATS.

EFFLUENT PUMPING SYSTEM - DUAL COMPARTMENT DRAWDOWN 1500 GAL. TANKS OR LARGER

ORENCO SYSTEMS INCORPORATED
 814 AIRWAY AVENUE
 SUTHERLIN, OREGON
 97479-9012

REFER TO PART IV AND PART V OF THE RULES, REGULATIONS, RATES & POLICIES FOR THE GOVERNING OF THE WATER & SEWER DEPARTMENT OF THE CITY OF MARYVILLE, TENNESSEE FOR FURTHER DETAILS. PART IV DEALS WITH THE INSTALLATION AND OPERATION OF THE PROPERTY OWNERS PUMP AND LINES. PART V DEALS WITH THE INSTALLATION AND OPERATION OF THE CITY OF MARYVILLE FORCE MAIN - COLLECTION LINES.

ALL REFERENCES TO A SPECIFIC PRODUCT OR TRADEMARK ARE FOR EXAMPLE ONLY - ALL MATERIALS ARE TO BE "AS SHOWN OR EQUAL APPROVED BY THE CITY OF MARYVILLE WATER & SEWER DEPARTMENT AND THE STATE OF TENNESSEE FOR USE IN SEPTIC TANK EFFLUENT PUMP SYSTEMS."



**WATER & SEWER DEPARTMENT
 CITY OF MARYVILLE
 MARYVILLE, TENNESSEE**

DRAWN BY: GEF	TITLE: STANDARD S.T.E.P. SEWER DETAILS	SCALE: NONE
APP'D BY:		SHEET 1 of 1
DATE:		
LAST REV DATE: 10/28/25		
DESCRIPTION:		W.O.

APPENDIX II – DEDICATION AND TRANSFER

- Dedication and Transfer of Utility Lines, Easements, and Pertinent Facilities

DEDICATION AND TRANSFER OF UTILITY LINES, EASEMENTS, AND PERTINENT FACILITIES

This indenture, made and entered into on this ____ day of _____, _____, by and between _____, of Blount County Tennessee, party of the first part, (hereinafter referred to as "Developer") and CITY OF MARYVILLE, TENNESSEE of Blount County, Tennessee, party of the second part, (hereinafter referred to as "City").

WITNESSETH that whereas, said Developer has caused to be constructed the following described utility facilities, to wit:

(City of Maryville Water and Sewer Engineering Work Order Numbers);

WHEREAS, said Developer desires that said utility facility be attached to and become a part of the City's existing water/sanitary sewer system and desires to dedicate, transfer and convey said facilities, including all easements and rights connected therewith, to the City and has requested that the City accept the same into its system.

NOW, THEREFORE, in consideration of the City accepting said utility facilities into the City's system, said Developer hereby dedicates, transfers and conveys unto the City, its successors and assigns, all of the afore described utility facilities together with all easements and rights connected therewith.

The Developer further warrants that all labor and materials in connection with the construction and installation of said facilities have been fully and completely paid and that there are no liens or other encumbrances existing against said facilities.

The Developer further warrants that said utility facilities are free and clear of all defects in material and workmanship, that said facilities were constructed and installed in strict compliance with all requirements of the City's rules, regulations, and orders, and does hereby agree to indemnify and save harmless the City from any and all loss, costs, expense or damage which the City may suffer as a result of any defect or defects which occur in said facilities within one (1) year from the acceptance of this instrument.

APPENDIX III- WATER METERS

Standard for Testing Water Meters Accuracy Limit Chart

Reasons for Water Meter Tests –

To insure that the cost of water service is equitably distributed among all customers.

To prevent the loss of revenue to the Maryville Water and Sewer Department, which may occur if meters are not maintained at a reasonable level of efficiency.

Test Rates –

Three rates of flow are necessary under this Standard to properly test water meters of positive-displacement and compound types - maximum, intermediate, and minimum. The rates of flow for 5/8-inch and 1-inch displacement type meters and 2-inch compound meters are given in the table below.

Test Qualities –

The quantities of water necessary under this Standard to reduce testing errors to an acceptable minimum are given in the table below for 5/8-inch and 1-inch displacement type meters and 2-inch compound meters.

Accuracy Limits –

Accuracy limits are established under this Standard to ensure that water meters record as accurately as commercially feasible. Accuracy limits for 5/8-inch and 1-inch displacement type meters and 2-inch compound meters are given in the table below.

Test Tanks, Periodic Tests, Records

STANDARD TEST FOR WATER METERS

Size (in.)	Rate of Flow (gpm)	Test Quantity (gal.)	Accuracy Limits* M	Rate of Flow (gpm)	Test Quantity (gal)	Accuracy Limits** M	Rate of Flow (gpm)	Test Quality (gal)	Accuracy Limits* (%)	
									New Meters	Repaired Meters**
5/8	15	100	98.5 – 101.5	2	10	98.5 – 101.5	1/4	10	95 – 101.5	90 - 101.5
1	40	100	98.5 – 101.5	4	10	98.5 – 101.5	3/4	10	95 – 101.5	90 - 101.5
2	120	1,000	97 - 103	15	100	97 - 103	1/4	10	95 – 102	90 - 103

* Accuracy limits for repaired, as well as new meter.

** The limits set for repaired meters are considered to represent those that require good meter shop procedures to achieve. Any meter, regardless of age, which cannot be repaired to test 90% or better on the minimum flow test shall not be placed in service.

Test Tanks –

Only commercial calibrated tanks providing an overall error of less than 0.3 percent shall be used when testing accuracy of water meters.

Periodic Tests –

To ensure reliable meter measurements, it is essential that all meters be subjected to periodic tests. Under average conditions the following intervals between tests should not be exceeded:

Meter Size (Inches)	Years Between Test
5/8	10
1	6
2	4

The simple rule to be applied once information on (1) sales value of water and wastewater charges, (2) the effect of City of Maryville water on meters, and (3) the net cost of meter removal, testing, repairing, and replacing is at hand can be stated as follows:

IN ANY PERIOD OF TIME, THE HIGHEST NET REVENUE FROM A METERED WATER SYSTEM IS RECEIVED WHEN THE COST OF METER REPAIR AND MAINTENANCE JUST EQUALS THE LOSS OF REVENUE IF SUCH WORK IS NOT DONE.

Records –

Individual records shall be maintained and kept on file during the life of each water meter. Records shall include test data, including meter readings, test dates, purchase dates, Maryville Water and Sewer Department company numbers, location of previous settings, and a cross filing system of records.