

- NOTES:
- M.H. DIA. SHALL BE 48" FOR 18" AND LESSER DIA. PIPE AND 60" FOR 21" THRU 30" DIA.
  - 6" CLASS "A" CONC. PAD FOR MH'S 12" DP. OR DEEPER. 8" MIN. TH. D.O.T. #67 OR #7 CRUSHED STONE FOR ALL MH'S.
  - M.H. STEPS SHALL BE ALUMINUM & ALIGNED OVER INLET OR OUTLET.
  - USE PRE-CAST CONC. RINGS TO BRING GRADE WHERE NECESSARY.
  - PAINT OUTSIDE WALLS W/ (2) COATS OF BITUMINOUS PAINT APPLIED @ RIGHT ANGLES TO EA. OTHER IF SPECIFIED BY ENGINEER.
  - COAT OUTSIDE OF ALL JOINTS W/ BITUMINOUS ROOFING MAT'L.
  - FLEXIBLE COUPLING(S) REQ'D. WHEN INSTALLING M.H. AT AN EXISTING SEWER MAIN.

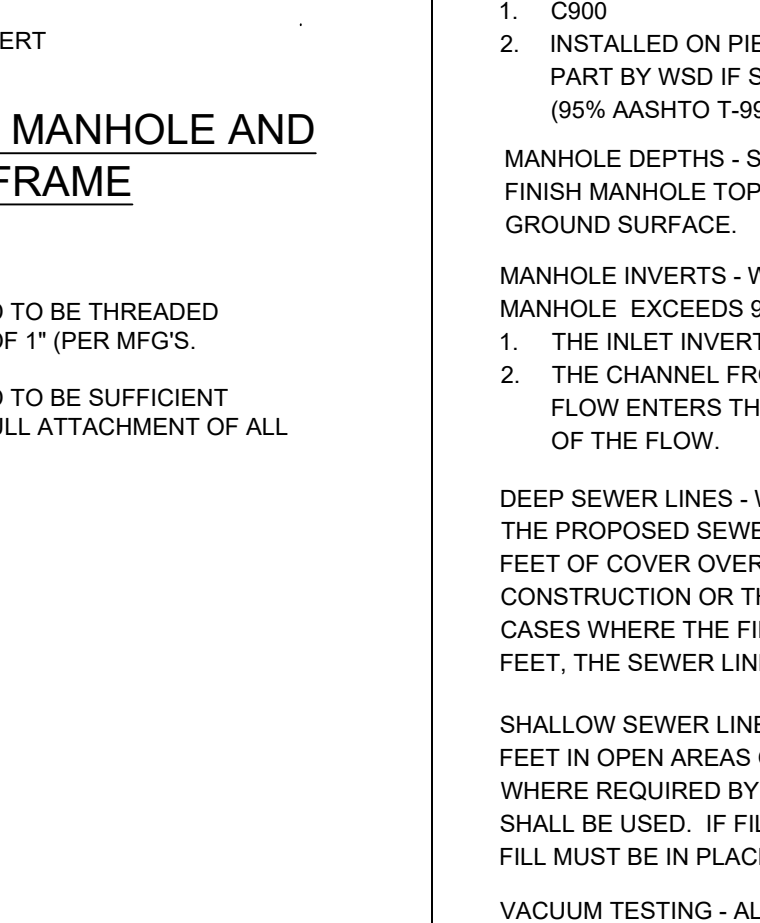
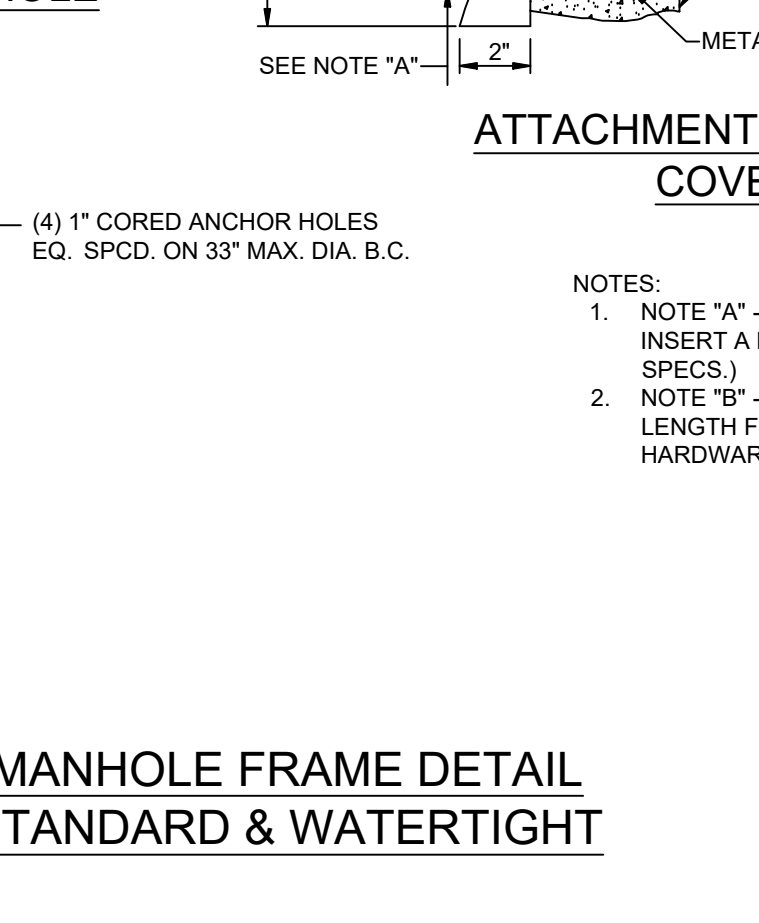
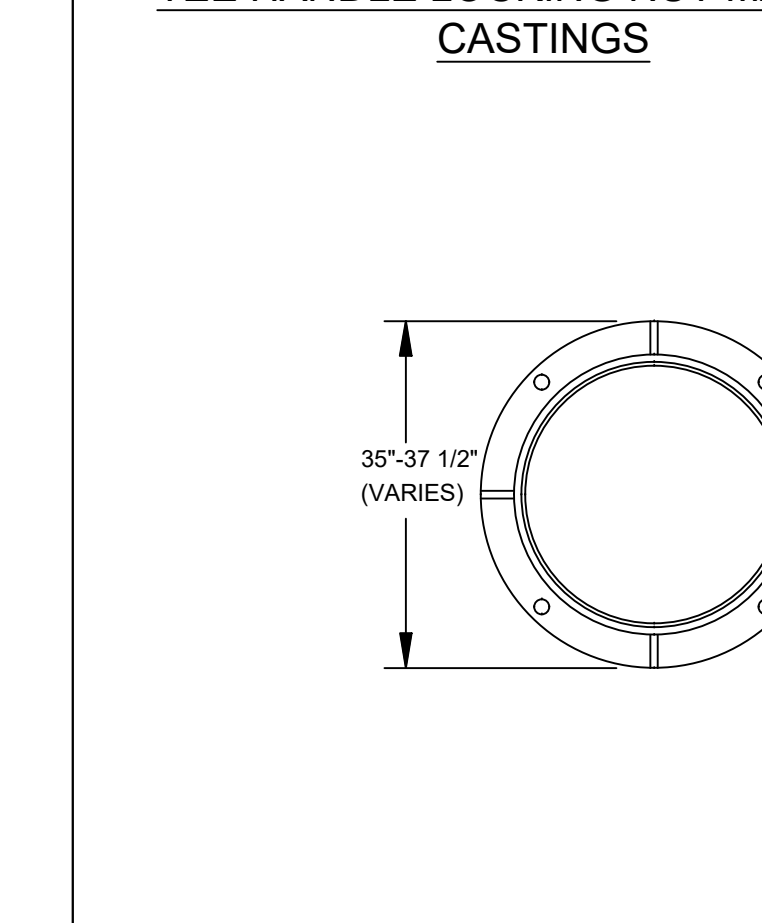
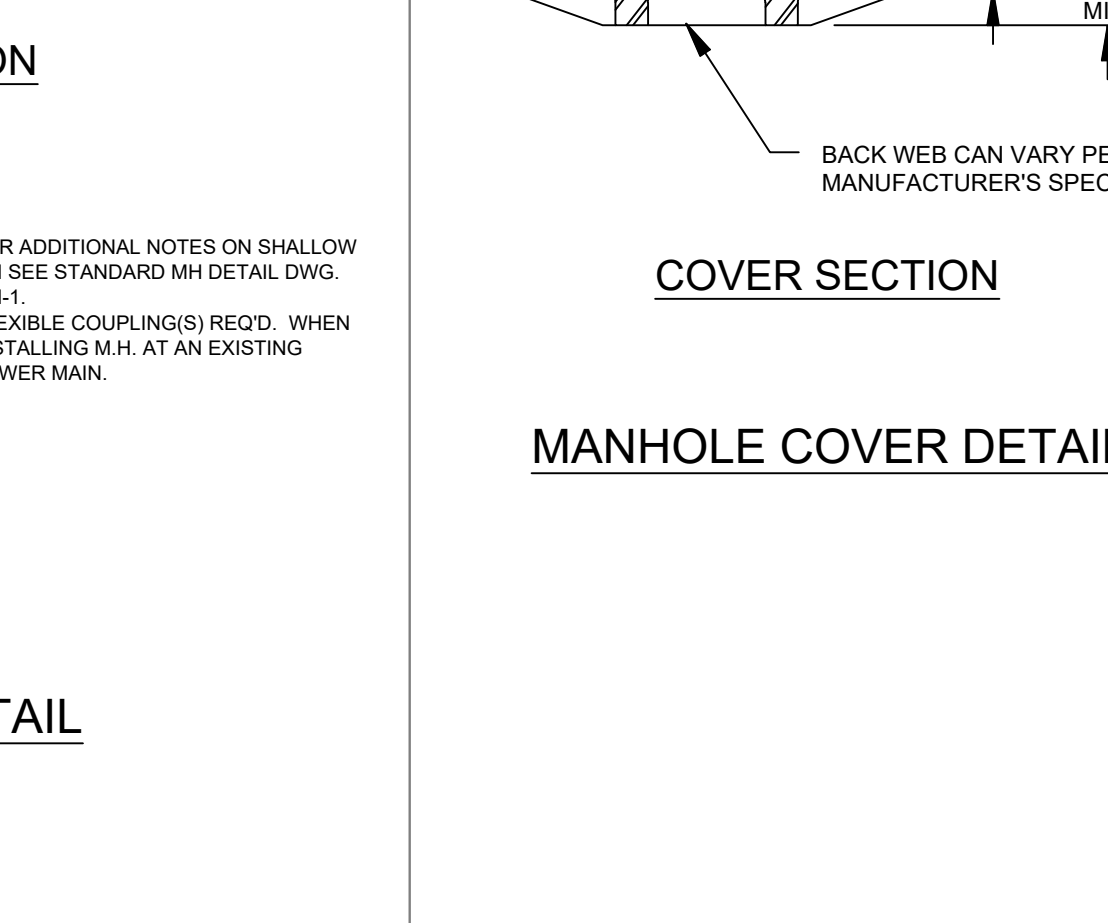
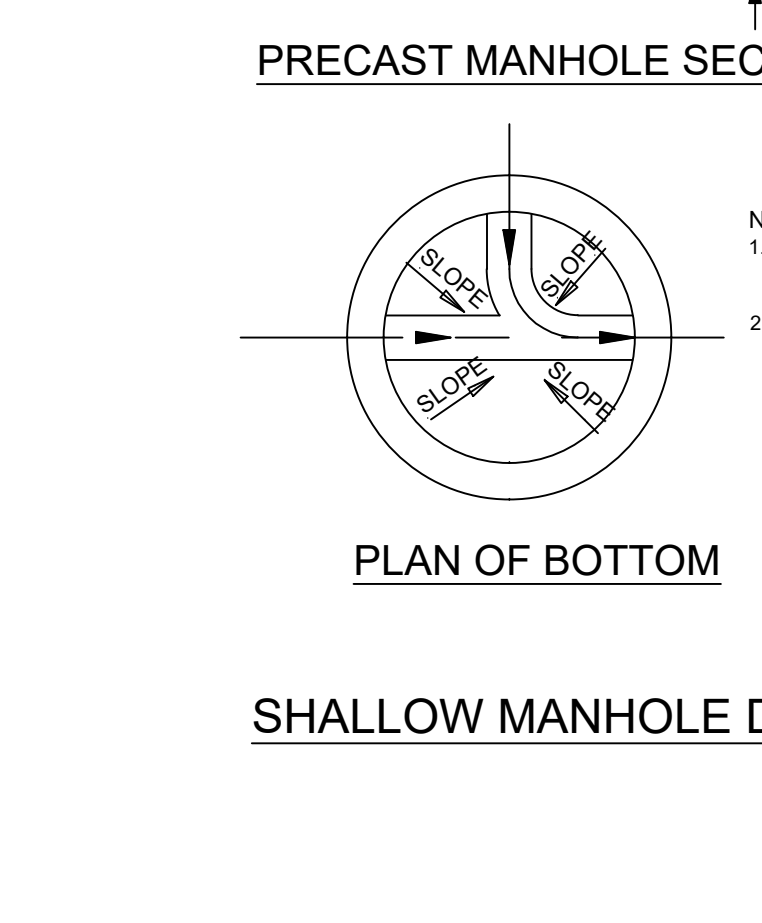
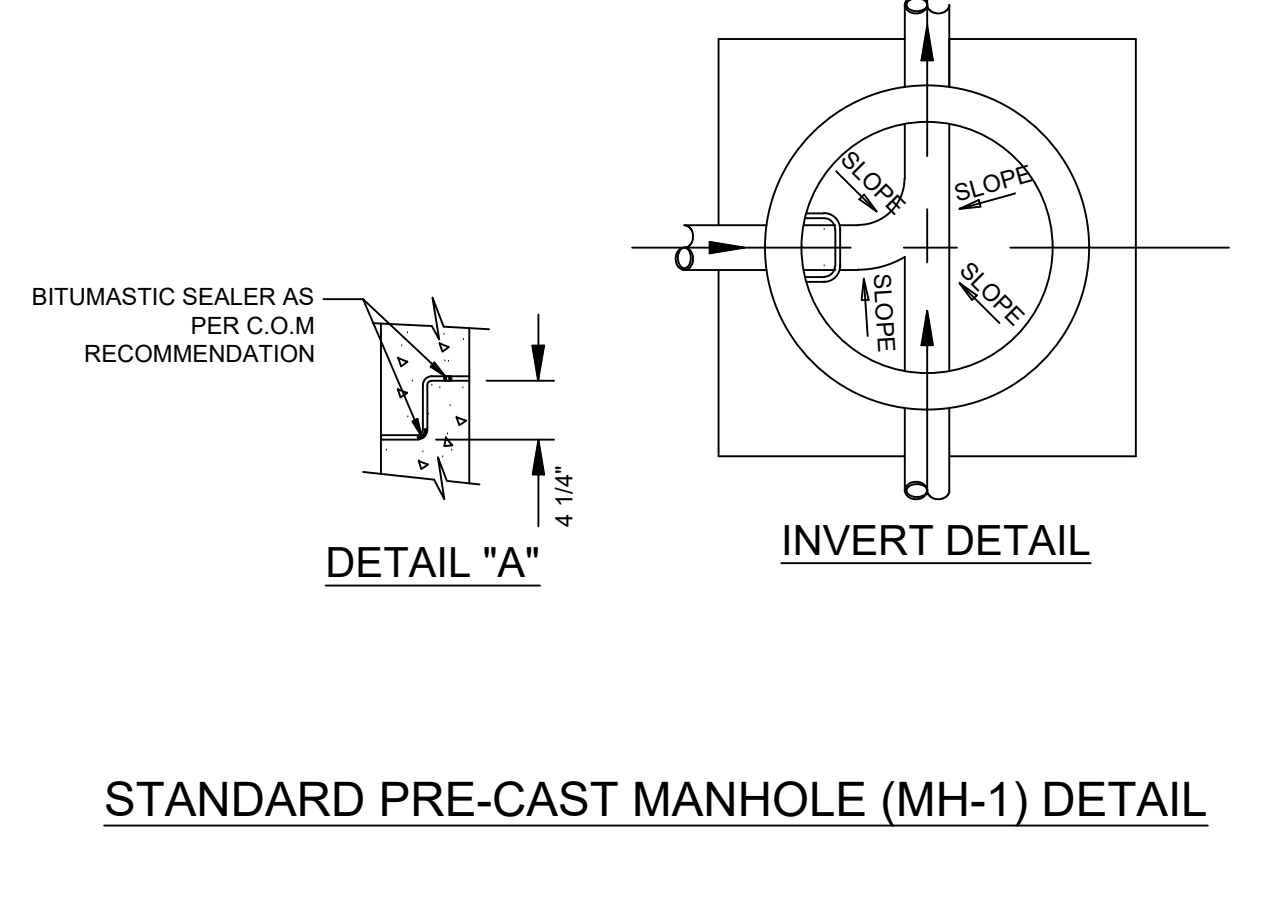
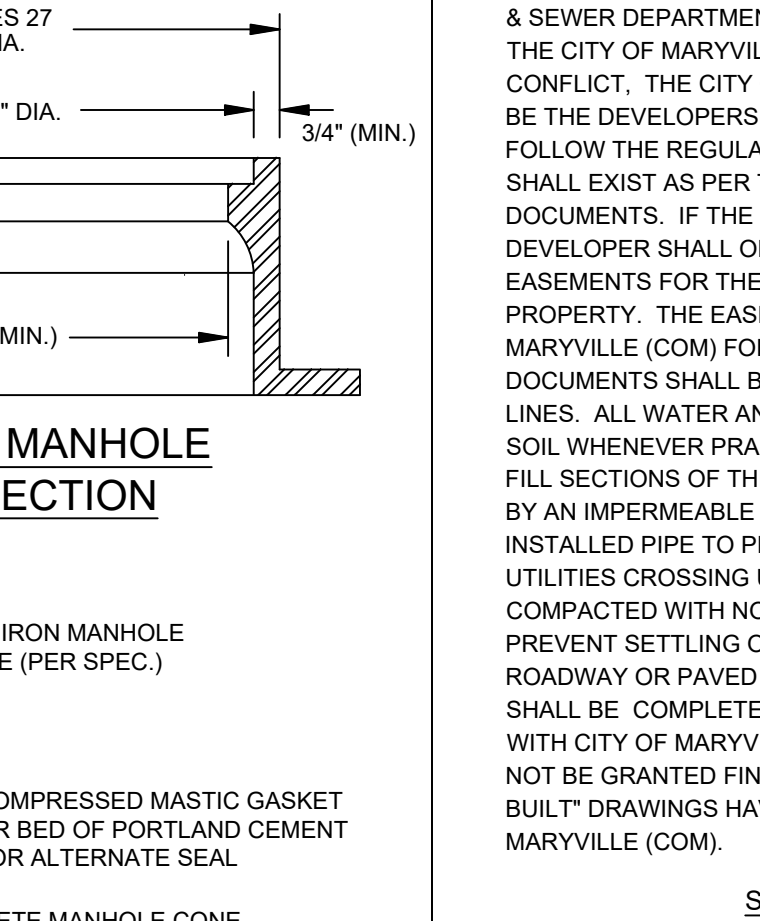
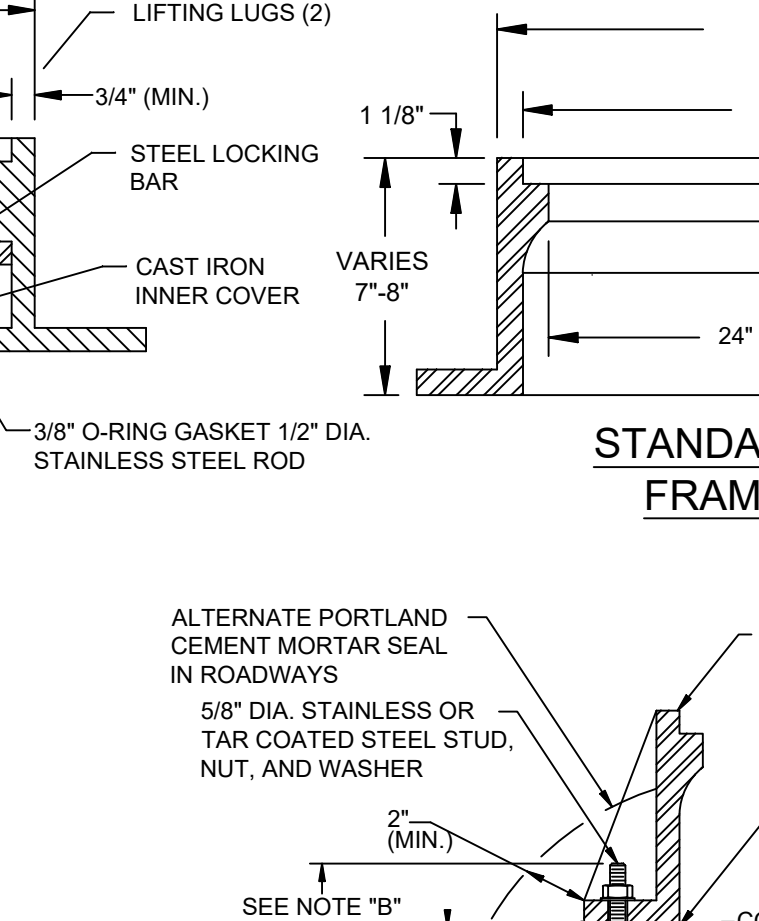
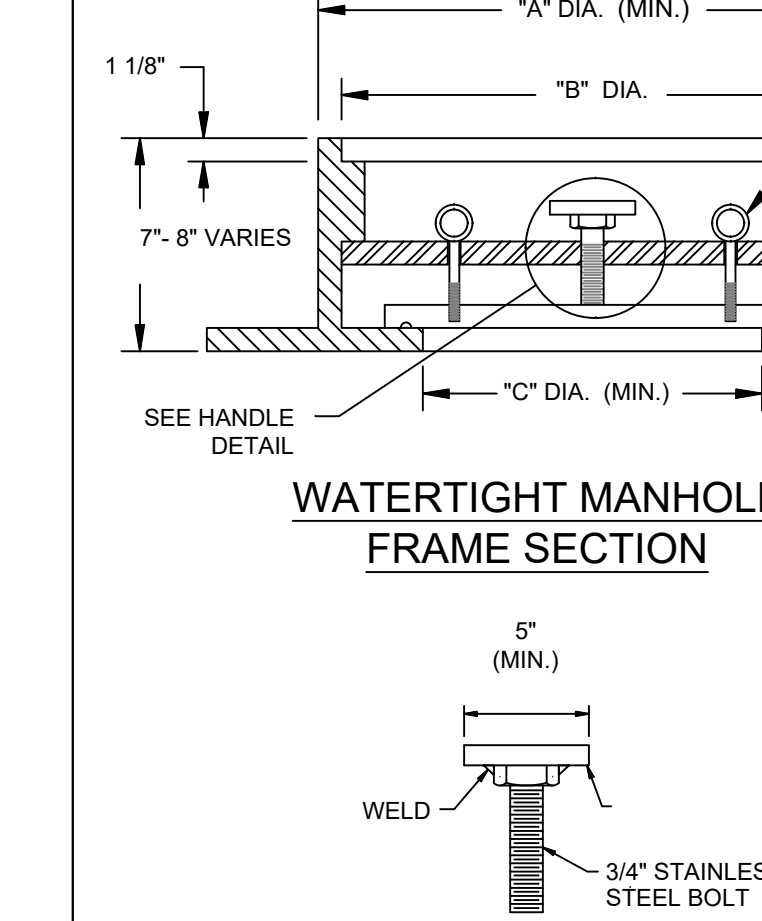
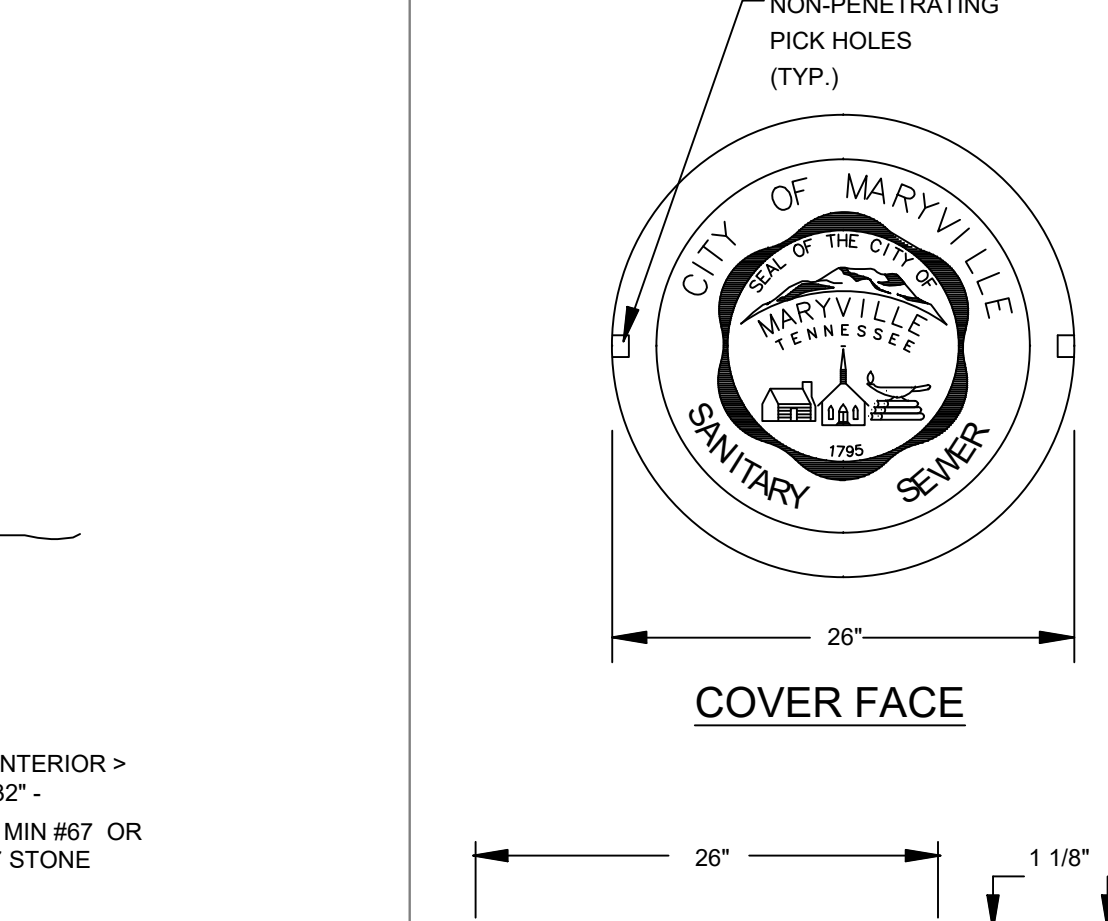
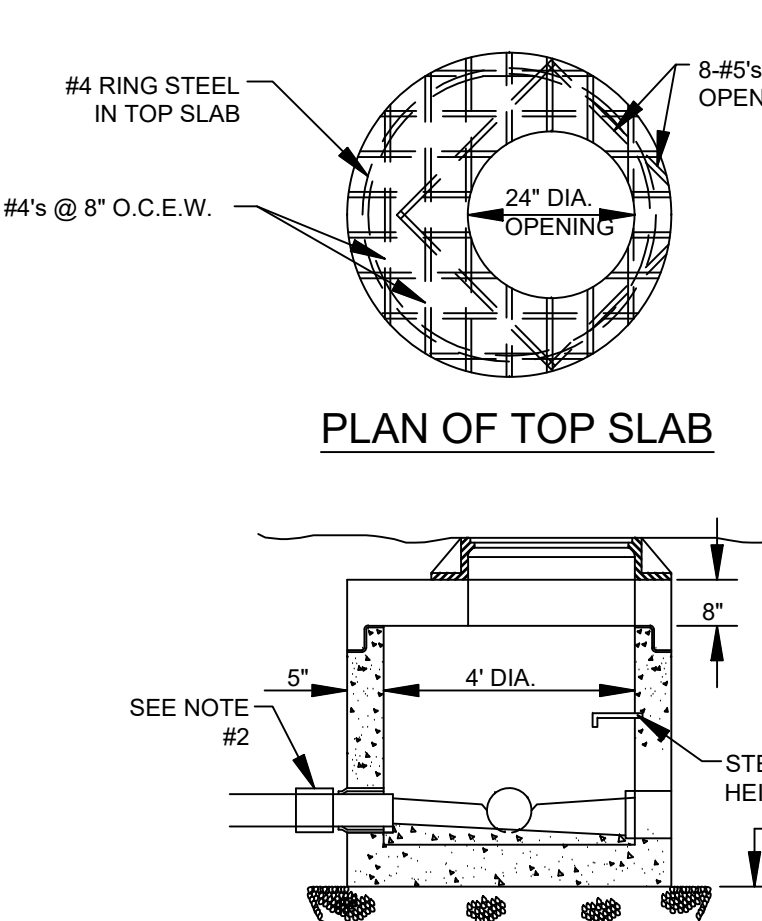
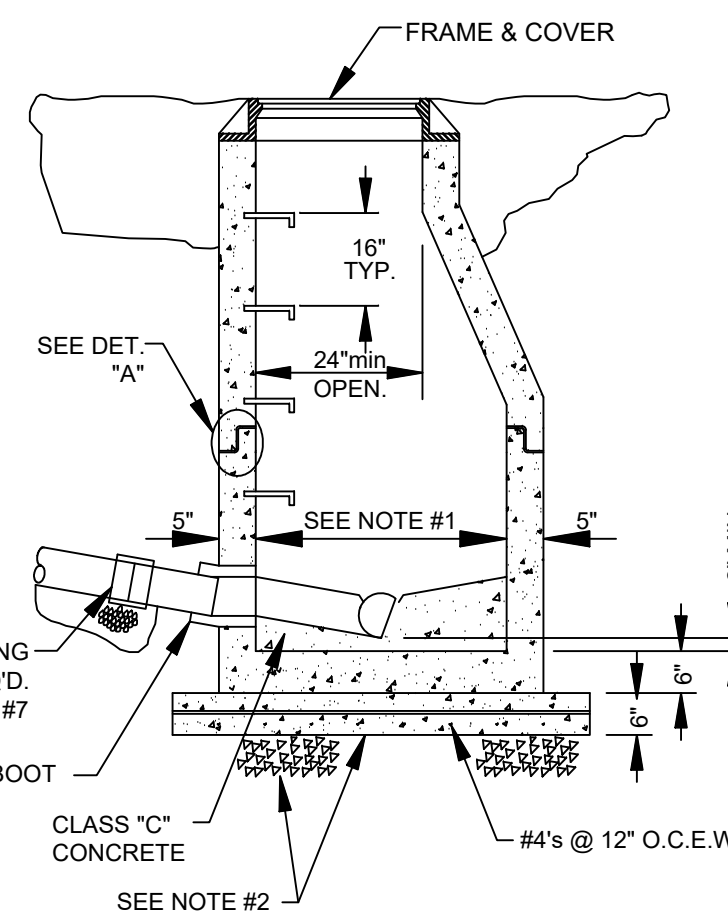

**CITY OF MARYVILLE**  
GENERAL UTILITY NOTES:

ALL SEWER AND WATER EXTENSIONS SHALL BE BUILT IN ACCORDANCE WITH THE RULES, REGULATIONS, RATES, AND POLICIES OF THE CITY OF MARYVILLE, WATER & SEWER DEPARTMENT, MARYVILLE, TENNESSEE WHICH ARE AVAILABLE FROM THE CITY OF MARYVILLE (COM) AT WWW.MARYVILLEGOV.COM. IN CASES OF CONFLICT, THE CITY OF MARYVILLE (COM) REGULATIONS SHALL RULE. IT SHALL BE THE DEVELOPERS AND CONTRACTORS RESPONSIBILITY TO OBTAIN AND FOLLOW THE REGULATIONS OF THE CITY OF MARYVILLE (COM). EASEMENTS SHALL EXIST AS PER THE SUBDIVISION PLAT OR RECORDED EASEMENTS DOCUMENTS. IF THE NECESSARY EASEMENTS ARE NOT IN PLACE, THE DEVELOPER SHALL OBTAIN AND FURNISH THE CITY OF MARYVILLE (COM) WITH EASEMENTS FOR THE PORTIONS OR UTILITY LINES THAT CROSS PRIVATE PROPERTY. THE EASEMENT DOCUMENTS SHALL BE REVIEWED BY THE CITY OF MARYVILLE (COM) FOR ACCEPTABILITY PRIOR TO SIGNATURES. ALL EASEMENT DOCUMENTS SHALL BE RECORDED PRIOR TO CONSTRUCTION OF THE UTILITY LINES. ALL WATER AND SEWER LINES SHALL BE LAID IN UNDISTURBED NATIVE SOIL WHENEVER PRACTICAL. AT THE JUNCTION OF ALL UNDISTURBED SOIL AND FILL SECTIONS OF THE PIPE TRENCH, THE BACKFILL MATERIAL SHALL BE DIVIDED BY AN IMPERMEABLE SECTION OF FILL (E.G. COMPACTED CLAY) AROUND THE INSTALLED PIPE TO PREVENT PIPING OF WATER THROUGH THE PIPE BEDDING. UTILITIES CROSSING UNDER OTHER UTILITIES SHALL BE BACK FILLED WITH COMPACTED WITH NO. 7 STONE TO THE SPRING LINE OF THE UPPER UTILITY TO PREVENT SETTLING OF THE UTILITY. ANY UTILITY TRENCH LOCATED WITHIN A ROADWAY OR PAVED AREA, INCLUDING PRIVATE DRIVES AND PARKING LOTS, SHALL BE COMPLETELY BACKFILLED WITH COMPACTED STONE IN ACCORDANCE WITH CITY OF MARYVILLE REQUIREMENTS. WATER AND SEWER SYSTEMS SHALL NOT BE DRAWING FINAL APPROVAL BY THE CITY OF MARYVILLE (COM) UNTIL "AS BUILT" DRAWINGS HAVE BEEN COMPLETED AND ARE ACCEPTABLE TO THE CITY OF MARYVILLE (COM).

**SANITARY SEWER SPECIAL NOTES:**

- SEWERS IN FILL - SEWER LINES LAID IN FILL SHALL BE:
  - C900
  - INSTALLED ON PIERS THIS REQUIREMENT MAY BE WAIVED IN WHOLE OR IN PART BY WSD IF SUFFICIENT COMPACTION HAS BEEN ACHIEVED IN THE FILL (95% AASHTO T-99 MINIMUM).

MANHOLE DEPTHS - SHALL BE THE CONTRACTORS RESPONSIBILITY TO BRING THE FINISH MANHOLE TOPS INTO CONFORMANCE WITH THE FINISH GRADE AND/OR GROUND SURFACE.

MANHOLE INVERTS - WHEN THE DEFLECTION ANGLE IN THE INVERT OF A MANHOLE EXCEEDS 90" THE CITY OF MARYVILLE (COM) REQUIRES THAT:

- THE INLET INVERT BE AT LEAST 2 INCHES HIGHER THAN THE OUTLET INVERT.
- THE CHANNEL FROM THE INLET TO THE OUTLET SHALL BE FORMED SO NO FLOW ENTERS THE MAIN FLOW STREAM COUNTER TO THE MAIN DIRECTION OF THE FLOW.

DEEP SEWER LINES - WHERE THE EXISTING COVER IS MORE THAN 16 FEET OVER THE PROPOSED SEWER LINE, THE GROUND MUST BE GRADED TO LESS THAN 16 FEET OF COVER OVER THE PROPOSED SEWER LINE PRIOR TO SEWER CONSTRUCTION OR THE SEWER LINE MUST BE CONSTRUCTED OF C900. IN ALL CASES WHERE THE FINAL COVER OVER THE SEWER LINE IS GREATER THAN 16 FEET, THE SEWER LINE SHALL BE CONSTRUCTED OF C900.

SHALLOW SEWER LINES - WHERE THE EXISTING COVER DEPTH IS LESS THAN 2 1/2 FEET IN OPEN AREAS OR 4 FEET IN ROADWAYS, THE UTILITY LINE SHALL BE C900. WHERE REQUIRED BY THE CITY OF MARYVILLE (COM) CONCRETE ENCASEMENTS SHALL BE USED. IF FILL IS USED TO MEET MINIMUM COVER REQUIREMENTS, THE FILL MUST BE IN PLACE PRIOR TO UTILITY LINE INSTALLATION.

VACUUM TESTING - ALL MANHOLES WILL BE VACUUM TESTED AS PER THE CITY OF MARYVILLE (COM) AS PER THE CITY OF MARYVILLE AND STATE OF TENNESSEE REQUIREMENTS PRIOR TO ACCEPTANCE.

TRENCH DAMS - TRENCH DAMS SHALL BE INSTALLED IN THE BEDDING AND BACKFILL AT ALL JUNCTIONS OF FILL AND NATIVE SOIL, AND UPSTREAM OF EACH MANHOLE TO LIMIT THE FRENCH DRAIN EFFECT OF THE GRAVEL BEDDING. THE MAXIMUM SPACING BETWEEN TRENCH DAMS SHALL BE 500 FEET. TRENCH DAMS SHALL CONSIST OF 4,000 PSI CONCRETE AND BACKFILL AT LEAST THREE FEET THICK TO THE TOP OF THE TRENCH AND CUT INTO THE WALLS OF THE TRENCH TWO FEET.

TEES AND LATERALS - ALL TEES AND LATERALS CONNECTED TO C900 SEWER MAINS AND ALL LATERALS CONNECTED TO MANHOLES, 16 FEET OR MORE IN DEPTH, SHALL BE C900.

MANHOLE COUPLINGS - ALL MANHOLE COUPLINGS (BOOTS) SHALL BE "STEEL BAND FERNCO BOOTS" WHENEVER THE SLOPE OF THE LINE ENTERING OR EXISTING THE MANHOLE IS 10% OR GREATER.

TRENCH BOTTOM CONDITIONS - TRENCH BOTTOM MAY BE REQUIRED TO BE UNDERCUT TO A FIRM BASE AND BACK FILLED WITH STONE TO PREVENT SETTLING IN AREAS OF UNSATISFACTORY MATERIAL. SUCH A DETERMINATION WILL BE MADE BY THE CITY OF MARYVILLE (COM) AT THE TIME OF CONSTRUCTION.

**SPECIFICATIONS:**

- LOAD RATING: HEAVY DUTY
- MATERIAL SPECIFICATION: ASTM-A48 CLASS 30
- TOTAL WEIGHT OF FRAMES & COVERS: STANDARD: 375 LBS. (MIN.) WATERTIGHT: 485 LBS. (MIN.)
- COVER FACE SHALL BE EMBOSSED WITH THE SEAL OF THE CITY OF MARYVILLE AS SHOWN.
- MANHOLE FRAME & COVER VENDOR DWGS. SHALL BE SUBMITTED TO THE WATER & SEWER DEPT. (WSD) PRIOR TO ORDERING MATERIALS. OPENING MUST MEET WSD REQUIREMENTS FOR ACCESS WHICH MAY VARY WITH SIZE OF AIR RELEASE VALVE, TRAFFIC CONDITIONS, DEPTH OF LINE, AND OTHER ON SITE CONDITIONS.
- GENERALLY A STD. FRAME AND GRATE, OR BILCO TYPE HATCH WITH A 24"x24" OR LARGER OPENING WILL BE REQUIRED. VERIFY TYPE OF ACCESS, OPENING SIZE, AND MATERIAL WITH WSD PRIOR TO ORDERING THE PRECAST FLAT TOP. UNAPPROVED ACCESS MAYBE REJECTED BY THE CITY OF MARYVILLE.

**ADDITIONAL NOTES:**

- ALL MH PARTS TO MEET C.O.M. STANDARDS
- PERFORATED COVER MAY BE USED IN LIEU VENTS WITH C.O.M. APPROVAL.
- CONTRACTOR TO VERIFY ADEQUATE SIZE OF MANHOLE FOR VALVE USED.
- VERIFY PROPOSED TOP ACCESS MATERIALS AND OPENING SIZE WITH WATER & SEWER DEPT. (WSD) PRIOR TO ORDERING MATERIALS. OPENING MUST MEET WSD REQUIREMENTS FOR ACCESS WHICH MAY VARY WITH SIZE OF AIR RELEASE VALVE, TRAFFIC CONDITIONS, DEPTH OF LINE, AND OTHER ON SITE CONDITIONS.
- GENERALLY A STD. FRAME AND GRATE, OR BILCO TYPE HATCH WITH A 24"x24" OR LARGER OPENING WILL BE REQUIRED. VERIFY TYPE OF ACCESS, OPENING SIZE, AND MATERIAL WITH WSD PRIOR TO ORDERING THE PRECAST FLAT TOP. UNAPPROVED ACCESS MAYBE REJECTED BY THE CITY OF MARYVILLE.

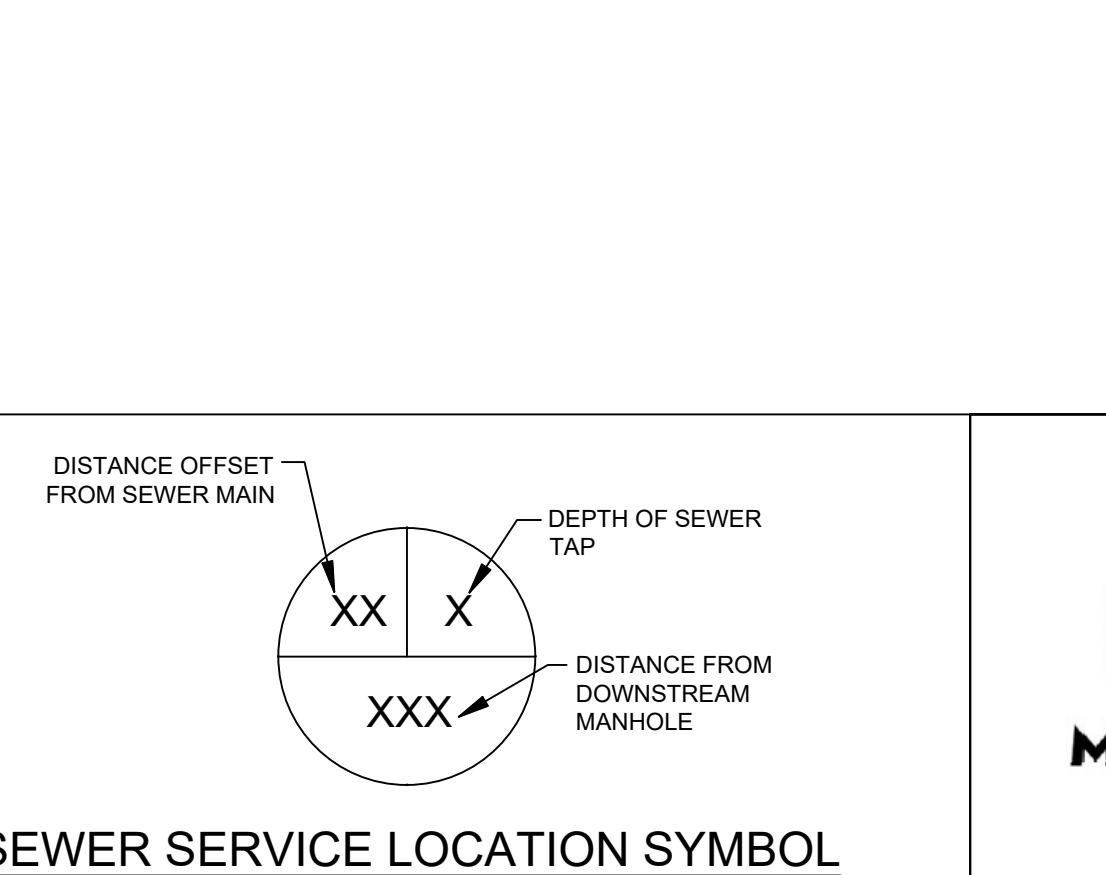
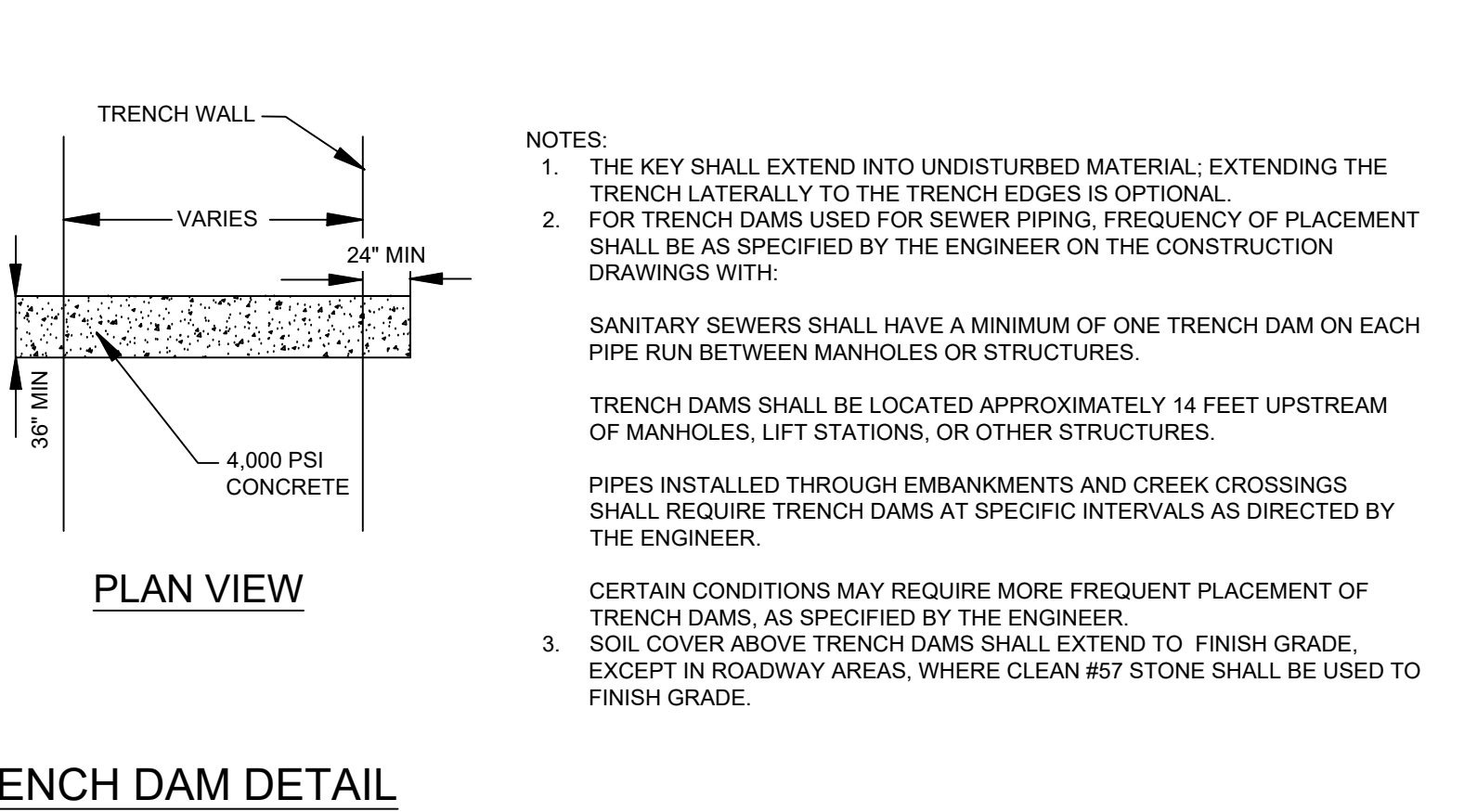
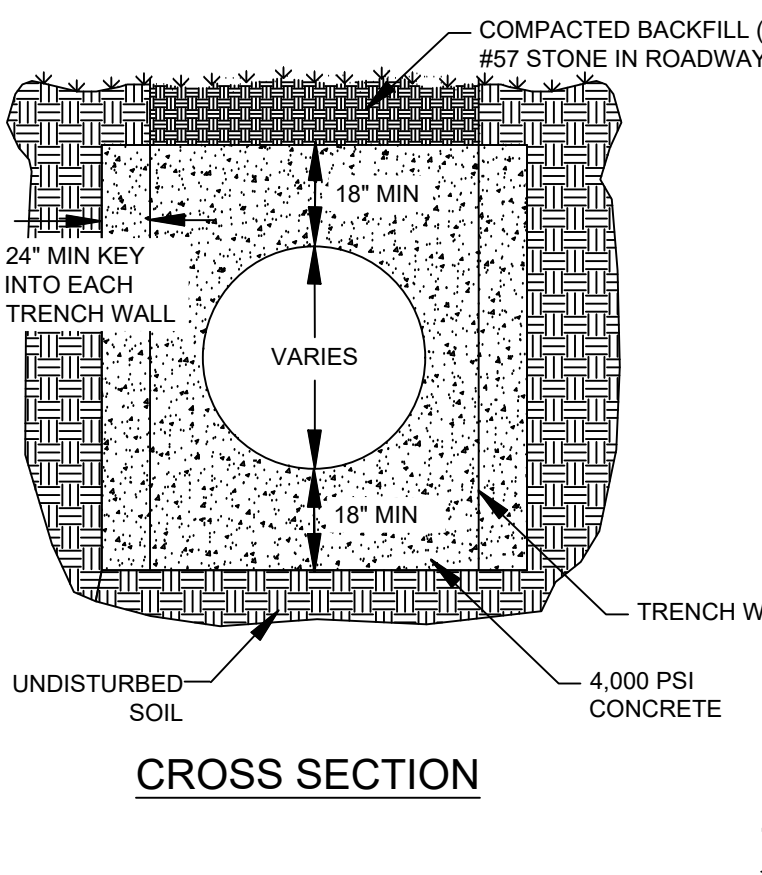
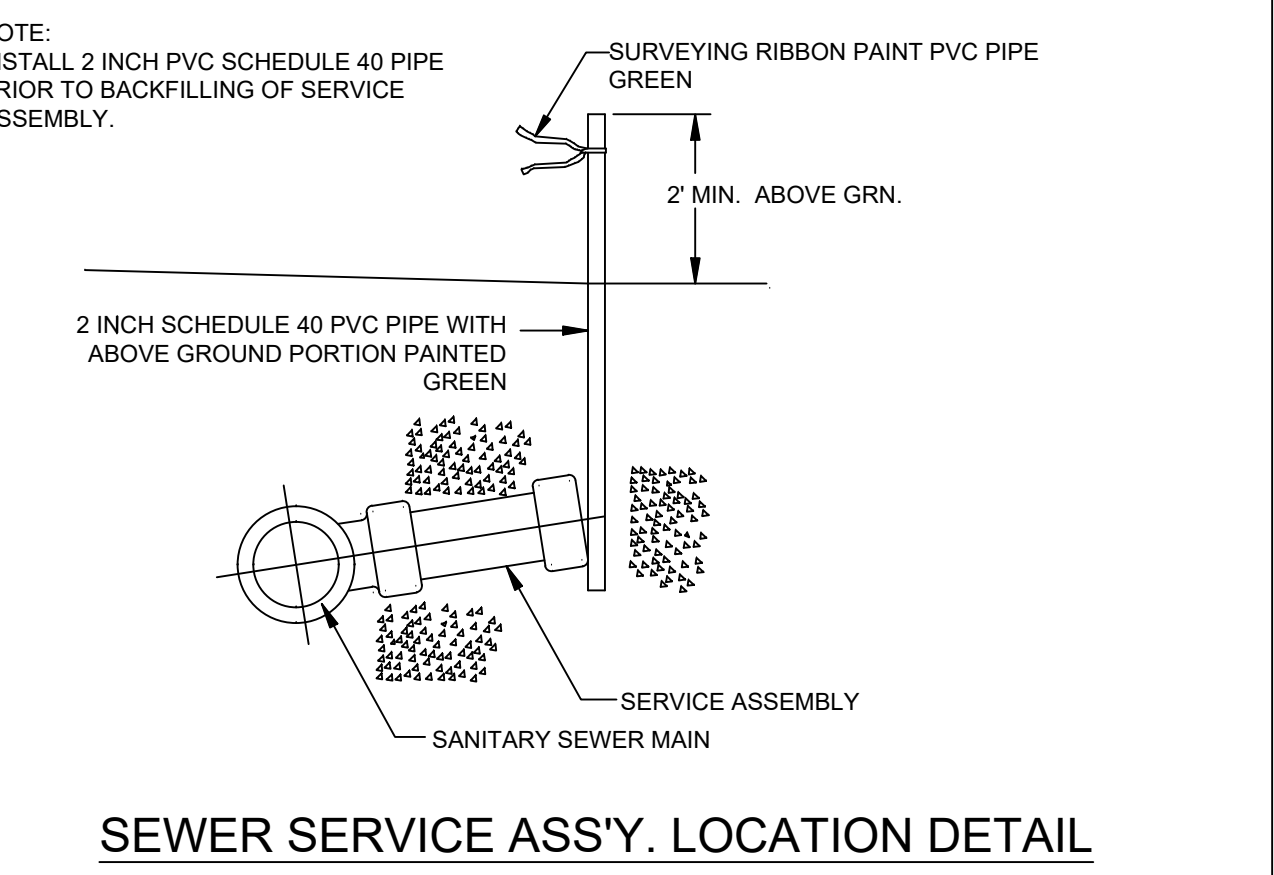
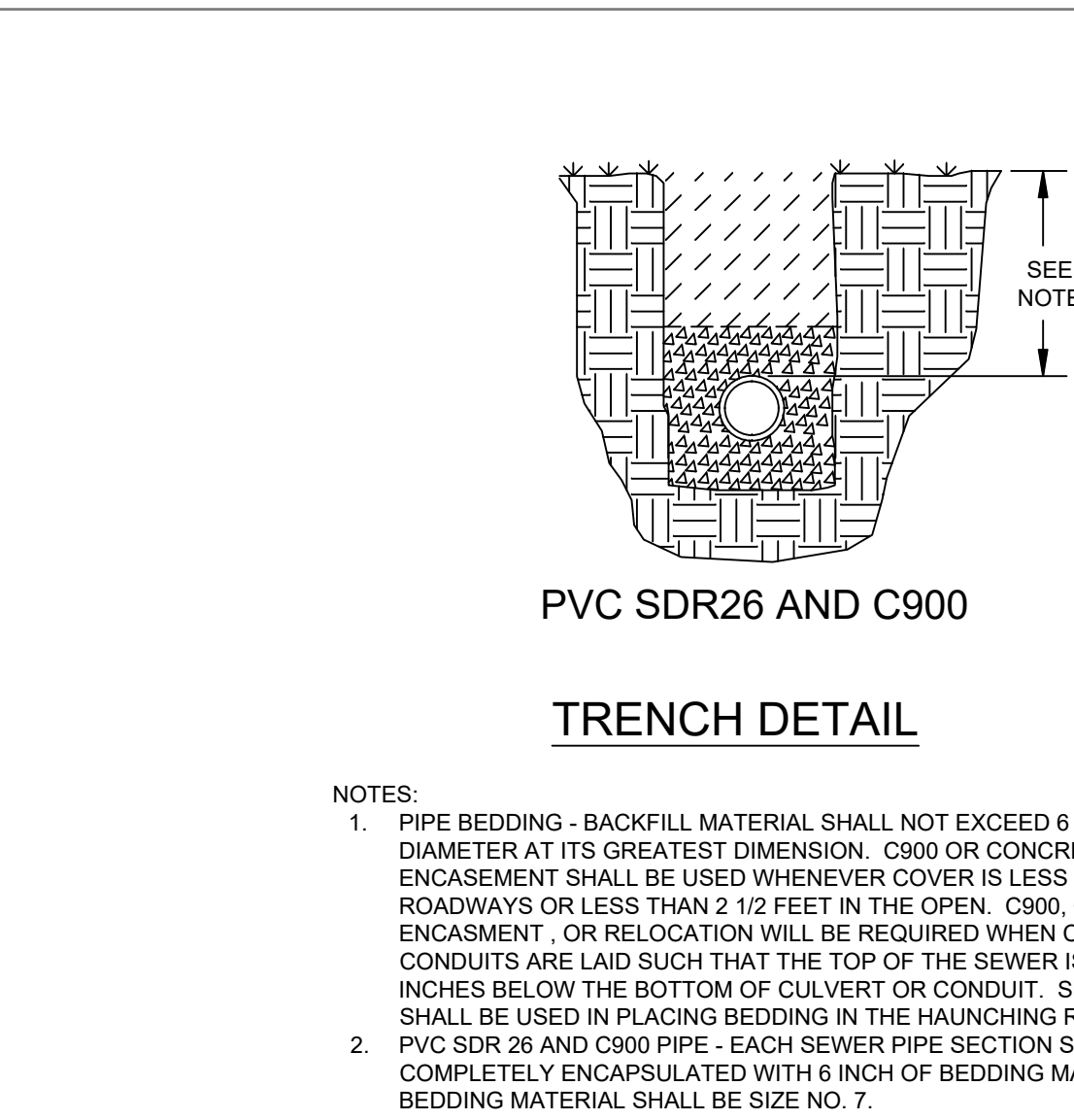
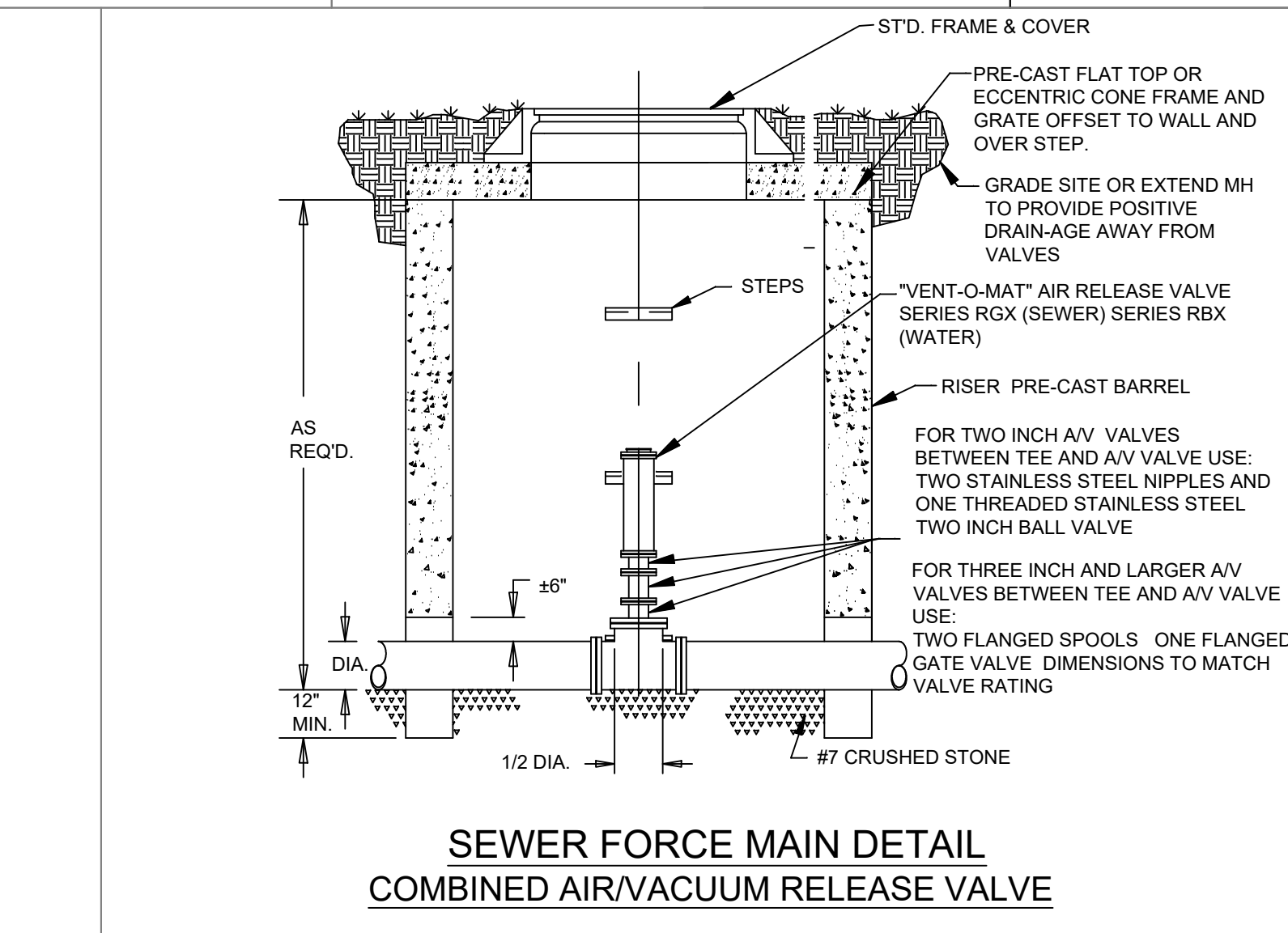
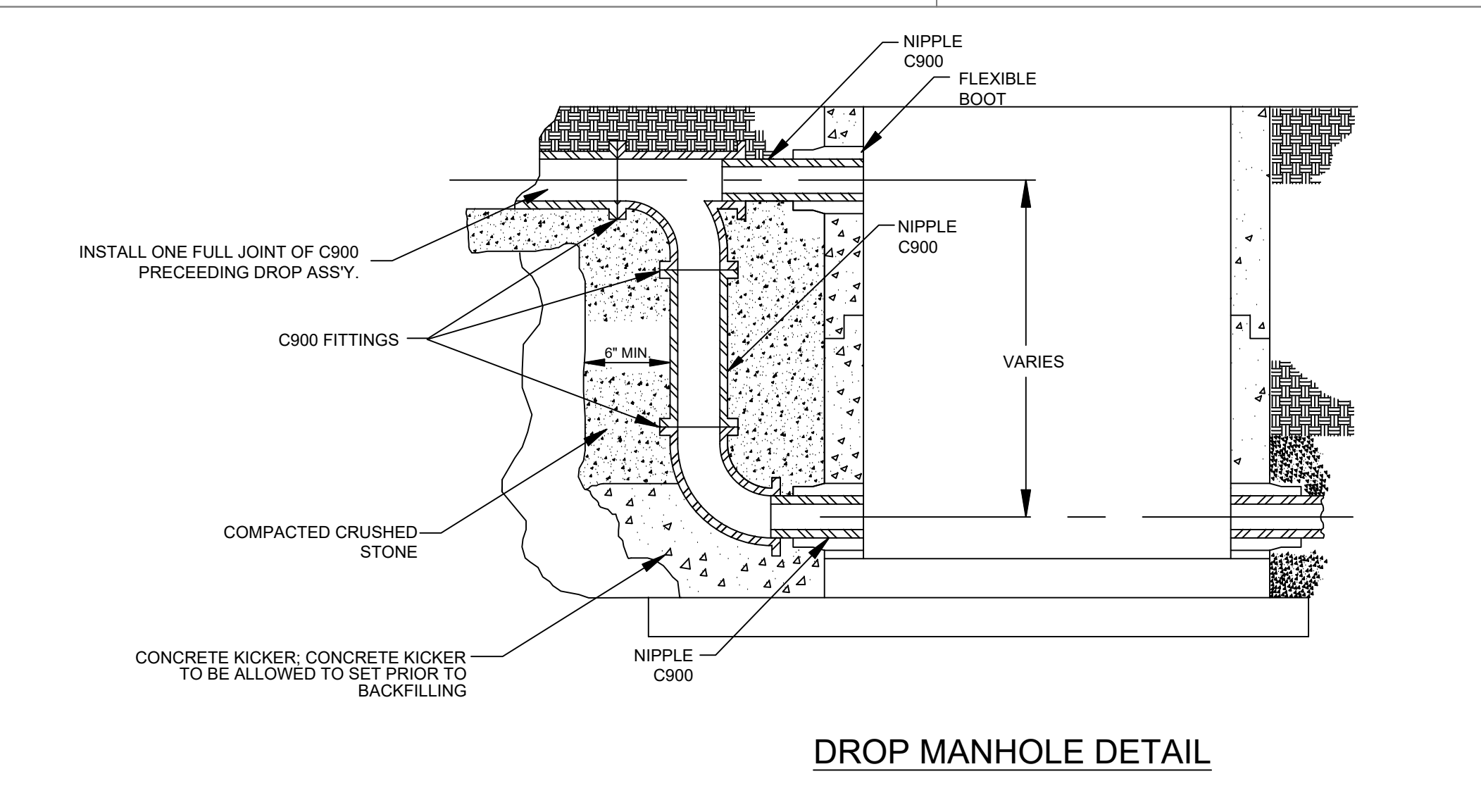

**WATER & SEWER DEPARTMENT**  
**CITY OF MARYVILLE**  
**MARYVILLE, TENNESSEE**

DRAWN BY: GEF TITLE: STANDARD DETAIL DWGS. SCALE: NONE  
 APP'D BY: JG SHEET 1 of 2  
 DATE: SEWER  
 LAST REV DATE: 10/28/25 DESCRIPTION: W.O.